



Programmable Controller CJ-series

# EtherNet/IP™ Connection Guide

## OMRON Corporation Industrial Handheld DPM Reader V460-H-series

Network  
Connection  
Guide

### **About Copyrights and Trademarks**

---

Microsoft product screen shots used with permission from Microsoft.

Windows is a registered trademark of Microsoft Corporation in the USA and other countries.

ODVA, EtherNet/IP are trademarks of ODVA.

Company names and product names in this document are the trademarks or registered trademarks of their respective companies.

---

## Contents

<b>1. Related Manuals</b>	<b>3</b>
<b>2. Terms and Definitions</b>	<b>4</b>
<b>3. Restrictions and Precautions</b>	<b>5</b>
<b>4. Overview</b>	<b>6</b>
<b>5. Applicable Devices and Device Configuration</b>	<b>7</b>
5.1. Applicable Devices	7
5.2. Device Configuration	8
<b>6. EtherNet/IP Settings</b>	<b>10</b>
6.1. Parameters	10
6.2. Assigning Tag Data Links	11
<b>7. EtherNet/IP Connection Procedure</b>	<b>13</b>
7.1. Operation Flow	13
7.2. Code Reader Setup	14
7.3. PLC Setup	17
7.4. Network Setup	27
7.5. Checking the EtherNet/IP Communications	40
<b>8. Initializing the System</b>	<b>46</b>
8.1. Initializing the PLC	46
8.2. Initializing the Code Reader	47
<b>9. Appendices How to Use the Project File</b>	<b>48</b>
9.1. Operation Flow	48
9.2. PLC Setup	49
<b>10. Revision History</b>	<b>51</b>

## 1. Related Manuals

To ensure system safety, make sure to read and follow the information provided in all *Safety Precautions* and *Precautions for Safe Use* in the manuals for each device which is used in the system.

The following OMRON Corporation (hereinafter referred to as “OMRON”) manuals are related to this document:

Cat. No.	Model	Manual name
W472	CJ2H-CPU6□-EIP CJ2H-CPU6□ CJ2M-CPU□□	CJ Series CJ2 CPU Unit Hardware User's Manual
W473	CJ2H-CPU6□-EIP CJ2H-CPU6□ CJ2M-CPU□□	CJ Series CJ2 CPU Unit Software User's Manual
W465	CS1W-EIP21 CJ1W-EIP21 CJ2H-CPU6□-EIP CJ2M-CPU3□	CJ Series EtherNet/IP Units Operation Manual
W446	CXONE-AL□□C-V4 / AL□□D-V4	CX-Programmer Operation Manual
W344	CXONE-AL□□C-V4 / AL□□D-V4	CX-Protocol Operation Manual
W474	CJ2□-CPU□□	CJ Series Instructions Reference Manual
Z461	V460-H Series	V460-H Industrial Handheld DPM Reader User Manual
Z462	V460-H Series	V460-H Industrial Handheld DPM Reader Communication Manual

## 2. Terms and Definitions

Below is a list of terms used in this manual and their definitions.

Term	Description/Definition
Node	It refers to a relay point, a branch point or a terminal on an EtherNet/IP network comprised of equipment having an EtherNet/IP port. Devices with one EtherNet/IP port are recognized as one node on the EtherNet/IP network, and devices with two EtherNet/IP ports are recognized as two nodes.
Tag	A tag is a unit that is used to exchange data with tag data links. Data is exchanged between the local network variables and remote network variables specified in the tags or between specified I/O memory areas.
Tag Set	When a tag data link connection is established, one or more tags (up to eight tags including the PLC status) are configured as a set. This is referred to as a Tag Set. Each tag set represents the unit of data that is linked for a tag data link connection. Tag data links are therefore created through a connection between one tag set and another tag set. A tag set name must be set for each tag set.
Tag Data Link	The Implicit communications of the EtherNet/IP standard is called a Tag Data Link. Tag data links enable cyclic tag data exchange between controllers or between a controller and other devices on an EtherNet/IP network.
Connection	A connection is used to exchange data as a unit within which data concurrency is maintained.
Connection Type	You can select multi-cast or unicast (point-to-point) as the connection type in the tag data link connection settings. Multi-cast sends an output tag set in one packet to more than one node. Unicast, on the other hand, individually sends one output tag set to each node. Therefore, using a multi-cast connection can decrease the communications load when sending one output tag to multiple nodes.
Originator and Target	To use tag data links, it is necessary to first establish a connection between the nodes that use them. The node that requests a connection is called the originator, and the node that receives the request is called the target.
Tag Data Link Parameters	In tag data link setting, "tag settings", "tag set settings" and "connection settings" are collectively called "tag data link parameters".
EDS File	It is a file describing device-specific information such as the number of input/output points for EtherNet/IP devices.

## 3. Restrictions and Precautions

- (1) Before building a system, understand the specifications of devices which are used in the system. Allow some margin for ratings and performance, and provide safety measures such as installing a safety circuit in order to minimize the risk in case of failure.
- (2) To ensure system safety, make sure to read and follow the information provided in all *Safety Precautions* and *Precautions for Safe Use* in the manuals for each device which is used in the system.
- (3) The user is encouraged to confirm the standards and regulations that the system must conform to.
- (4) It is prohibited to copy, to reproduce, and to distribute a part or the whole of this document without the permission of OMRON Corporation.
- (5) The information contained in this document is current as of November 2023. It is subject to change for improvement without notice.

The following notations are used in this document.

 <b>Caution</b>	Indicates a potentially hazardous situation which, if not avoided, may result in minor or moderate injury, or property damage.
--	--



### Precautions for Correct Use

Precautions on what to do and what not to do to ensure proper operation and performance.



### Note

Additional information to read as required.

This information is provided to increase understanding or make operation easier.

### Symbols



The triangle symbol indicates precautions (including warnings).

The specific operation is shown in the triangle and explained in text.

This example indicates a general precaution.

## 4. Overview

This document describes the procedures for connecting the Industrial Handheld DPM Reader products (V460-H Series) to a CJ Series Machine Automation Controller + EtherNet/IP Unit (PLC) via EtherNet/IP and for checking their connections.

Refer to *Section 6. EtherNet/IP Settings* and *Section 7. EtherNet/IP Connection Procedure* to understand setting methods and key points to operate EtherNet/IP tag data links.

In this document, the Built-in EtherNet/IP Ports of CJ Series EtherNet/IP Unit and CJ Series CJ2 CPU Unit are generically referred to as “EtherNet/IP Unit”.



### Note

The settings described in *7.3. PLC Setup* are already made in advance in the CX-Programmer project file (hereinafter referred to as “project file”) listed below. For how to use this project file, refer to *9. Appendices How to Use the Project File*. Obtain the latest version of the project file from OMRON Corporation.

Name	Filename	Version
CX-Programmer Project File (Ladder Program)	OMRON_V460_CJ_EIP_V100.cxp	Ver. 1.00
Network Configurator Project File	OMRON_V460_CJ_EIP_V100.nvf	Ver. 1.00

## 5. Applicable Devices and Device Configuration

### 5.1. Applicable Devices

The applicable devices that can be connected are as follows:

Manufacturer	Name	Model	Version
OMRON	CJ2 CPU Unit	CJ2□-CPU□□	Same or later version as indicated in section 5.2.
OMRON	EtherNet/IP Unit	CJ1W-EIP21 CJ2H-CPU6□-EIP CJ2M-CPU3□	
OMRON	Code reader	V460-H0PX	



#### Note

This document describes the procedures for establishing the network connections. It does not provide information on operation, installation, and wiring methods that are not directly related to the connection procedures. It also does not describe the function or operation of the equipment. Refer to the manuals or contact your OMRON representative.



#### Note

This document describes the procedures for establishing the communication connection of the device, and does not describe the operation, installation and wiring method of the device. For details on the above products (other than communication connection procedures), please refer to the instruction manual for the product or contact OMRON.



#### Precautions for Correct Use

The connection and connection check procedures described in this document use the devices listed in section 5.2, from among the above applicable devices.

You cannot use devices with versions earlier than the versions listed in section 5.2.

To use models that are not listed in section 5.2. or versions that are later than those listed in section 5.2., check the differences in the specifications according to their instruction manuals before operating the devices.



**5.2. Device Configuration**

The system components required for reproducing the connection procedures described in this document are as follows.

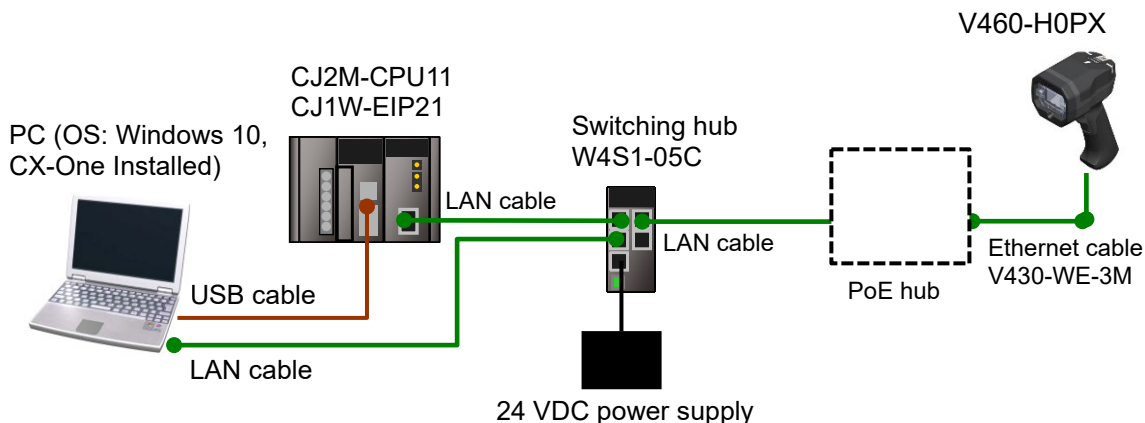

Manufacturer	Name	Model	Version
OMRON	CPU Unit	CJ2M-CPU11	Ver. 2.0
OMRON	Ethernet Unit	CJ1W-EIP21	Ver. 1.5
OMRON	Power Supply Unit	CJ1W-PA202	---
OMRON	Switching hub	W4S1-05C	Ver. 1.00
---	24 VDC power supply (for switching hub)	---	---
OMRON	CX-One	CXONE-AL□□C-V4 /AL□□D-V4	Ver. 4.□□
OMRON	CX-Programmer	(Included with CX-One)	Ver. 9.72
OMRON	Network Configurator	(Included with CX-One)	Ver. 3.70
OMRON	CX-Programmer Project File (Ladder Program)	OMRON_V460_CJ_EIP_ V100.cxp	Ver. 1.00
OMRON	Network Configurator Project File	OMRON_V460_CJ_EIP_ V100.nvf	Ver. 1.00
---	PC (OS: Windows 10)	---	---
---	USB cable (USB 2.0-compliant B-type connector)	---	---
OMRON	Ethernet cable	V430-WE-3M	---
---	LAN cable (Standard Ethernet cable)	---	---
OMRON	Code reader	V460-H0PX	Ver. 1.0
---	Single port PoE injector	98-9000311-01	---
---	24 VDC power supply	---	---



### **Precautions for Correct Use**

---

Ensure that the CX-Programmer and Network Configurator are updated to the versions specified in this section or higher.

If you use versions other than the versions specified in this section, there may be differences in the procedures in Section 7 and later. In that case, refer to the *CX-Programmer Operation Manual* (Cat. No. W446) or the *Network-Configurator Online Help* to perform the equivalent procedures.

---



### **Note**

---

Refer to the *Industrial Switching Hub W4S1 Series User Manual* (0969584-7) for power supply specifications that can be used for 24 VDC power supply (for the switching hub).

---



### **Note**

---

This document assumes that the USB is used to connect the PLC. For details on installing the USB driver, refer to *Appendices A-5 Installing the USB Driver* in the *CJ Series CJ2 CPU Unit Hardware User's Manual* (Cat. No. W472).

---

## 6. EtherNet/IP Settings

This section shows the specifications of the parameters and tag sets that you set in this document.

### 6.1. Parameters

The parameters that you set in this document are shown below.

#### 6.1.1. EtherNet/IP Communication Settings

The parameters used for connecting the PLC and the code reader via EtherNet/IP are as follows.

Parameter name	PLC (Node1)	Code reader (Node2)
Unit number	0	---
Node address	1	2
IP Settings	---	Fixed
IP address	192.168.188.1	192.168.188.2
Subnet mask	255.255.255.0	255.255.255.0
Gateway	---	0.0.0.0 (default), any value
IP Address Mode	---	Fixed
EtherNet/IP	---	Enabled

\* For the use cases in this document, setting the gateway is unnecessary because the devices are connected within the same segment of the network.

Set the code reader's gateway setting to any value. It must not be left blank.

#### 6.1.2. About the Code Reader Assemblies

The code reader has six types of Input Assemblies and two types of Output Assemblies, and one type can be selected for each.

The data structure changes based on the selected assembly.

Assembly Type	Assembly Name	Assembly Number
Input Assembly	Small Input Assembly	100
Input Assembly	Large Input Assembly	101
Input Assembly	MXL/SLC Input Assembly	102
Input Assembly	1 Decode Assembly	103
Input Assembly	4 Decode Assembly	104
Input Assembly	N Decode Assembly	105
Output Assembly	Output Assembly	197
Output Assembly	Output Assembly (Legacy)	198

For a detailed explanation of memory allocation and the data structure of each assembly, refer to *Appendices A-2 EtherNet/IP Specifications* in the *V460-H Industrial Handheld DPM Reader Communication Manual* (Cat. No. Z462).

## 6.2. Assigning Tag Data Links

This section describes how to assign tag data links for the code reader.

It shows the tag data link assignments with the following assemblies.

- Input Assembly: 1 Decode Input Assembly (103)
- Output Assembly: Output Assembly (197)

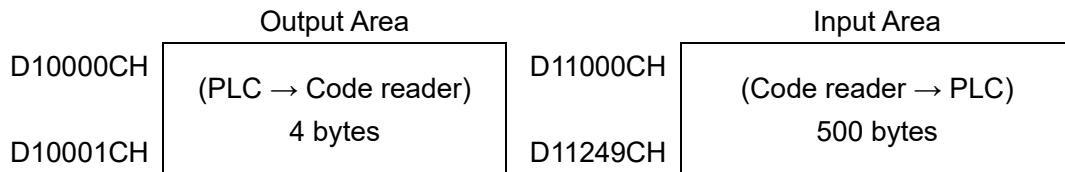

### ■ Output Area Description

Address	Bit															Description	
	15	14	13	12	11	10	9	8	7	6	5	4	3	2	1		0
D10000	---	---	---	---	---	---	---	---	---	---	---	---	---	---	Trigger	---	Status Signal (32 bits)
D10001	---	---	---	---	---	---	---	---	---	---	---	---	---	---	---	---	

■ Input Area Description

Address	Bit																Description
	15	14	13	12	11	10	9	8	7	6	5	4	3	2	1	0	
D11000	RESERVED								RESERVED								INFO BIT Diagnostics Sequence Count Information Configuration Change Detection Bit Reserved for future use
D11001	RESERVED								RESERVED								
D11002	DEVICE STATUS																Code Reader Signal Status Information
D11003																	
D11004	FAULT																Code Reader Error Code Information
D11005																	
D11006	COUNTERS																Read Count Information
..... D11017																	
D11018	READ CYCLE REPORT																Read Cycle Report Information
D11018 D11019 D11020																	
D11021	DECODE CYCLE REPORT																Decode Cycle Report Information
..... D11028																	
D11029	DECODE LENGTH																Length of decoded character string
D11030																	
D11031	DECODE DATA																Decoded data
..... D11249																	



**Note**

For more information on Command Codes and Response data, refer to *Appendices* in the *V460-H Industrial Handheld DPM Reader Communication Manual* (Cat. No. Z462).

## 7. EtherNet/IP Connection Procedure

This section describes the procedures for connecting the code reader and the PLC on an EtherNet/IP network.

In this document, it is assumed that the PLC and the code reader use the factory default settings. For how to initialize the devices, refer to *Section 8. Initializing the System*.

### 7.1. Operation Flow

The procedures for setting up the EtherNet/IP tag data links are as follows.

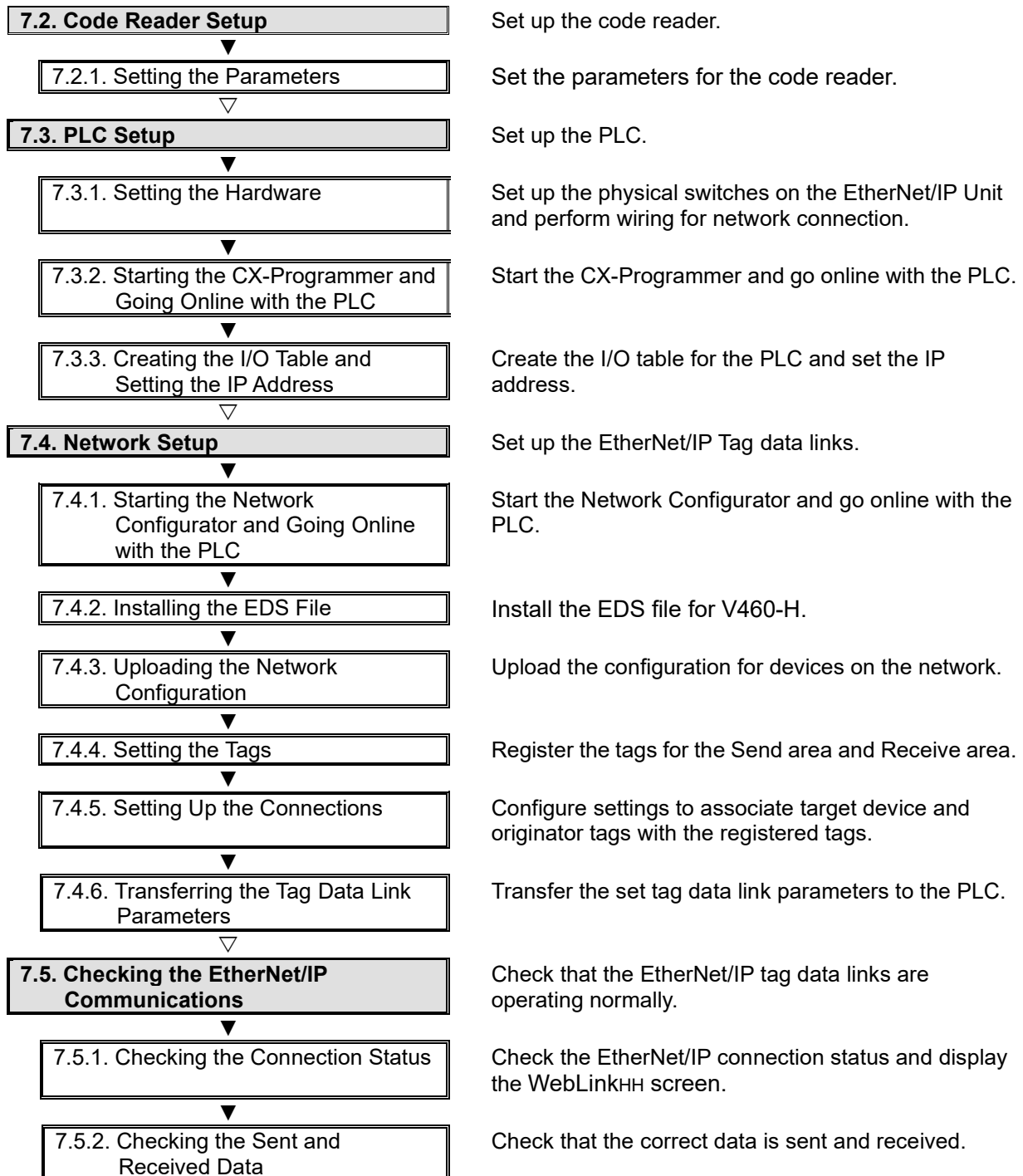

## 7.2. Code Reader Setup

Set up the code reader.

### 7.2.1. Setting the Parameters

Set the parameters for the code reader.

Set the IP address of your PC to *192.168.188.100* and its subnet mask to *255.255.0.0*.

- 1 Connect the cord reader and the switching hub to the PoE injector with cables.

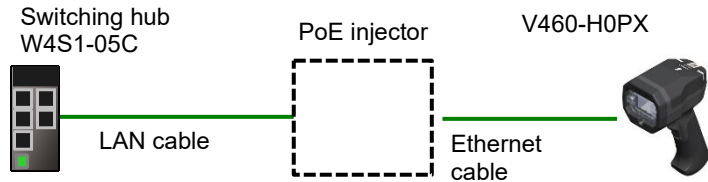

- 2 Connect the PC to the switching hub with a LAN cable.

Connect 24 VDC power supply (for the switching hub) to the switching hub.

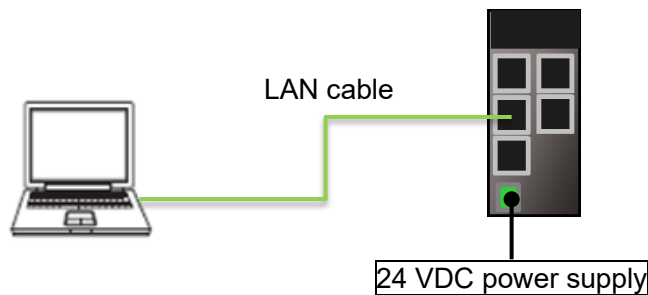

- 3 Set the IP Address of the PC.

For the IP address, enter *192.168.188.100*. For the subnet mask, enter *255.255.255.0*.

For the procedure to open the screen on the right, please refer to step 4.

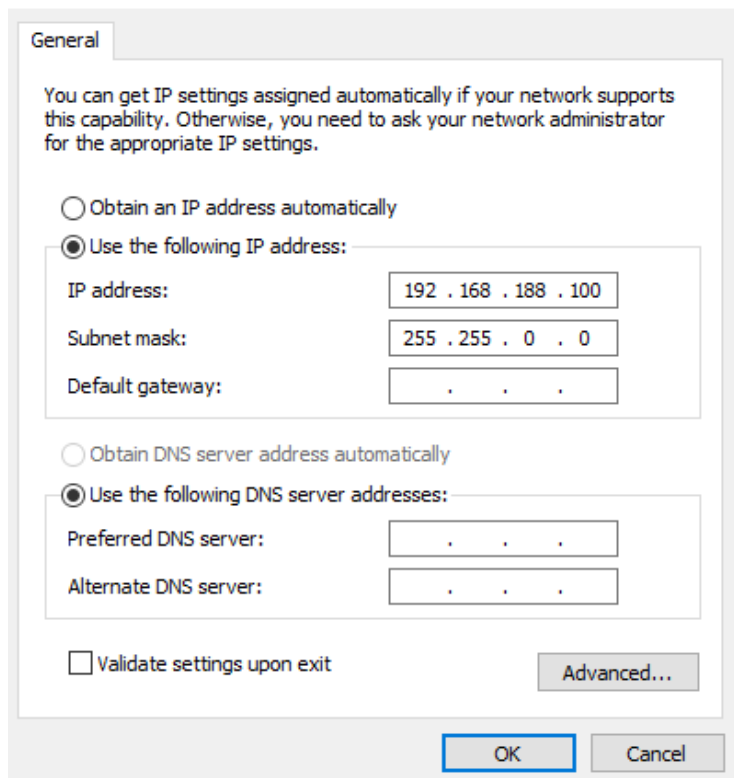

- 4** Static connection (Setting the fixed IP address)
- (1) From the Windows **Start Menu**, select **Control Panel – Network and Internet – Network and Sharing Center**.
  - (2) Click on **Local Area Connection**. The **Local Area Connection Status** Dialog Box is displayed. Click **Properties**.
  - (3) In the **Local Area Connection Properties** Dialog Box, select **Internet Protocol Version 4 (TCP/IPv4)**, and click the **Properties** Button. Set the IP Address of the PC to **192.168.188.100**.
  - (4) Click the **OK** Button.

- 5** Start your browser and enter **http://192.168.188.2**.  
“Google Chrome” is the recommended browser.

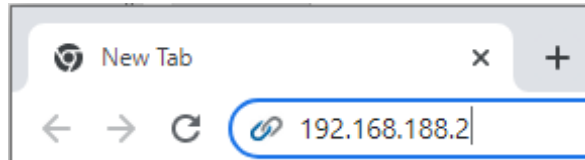

- 6** When the WebLinkHH startup screen is displayed, go to step 8.

If the WebLinkHH startup screen does not appear, go to step 7.



- 7** If the WebLinkHH startup screen does not appear, it means that communications are not established between the code reader and the PC. Please check the following.

- Does the code reader and the PC have a proper physical (cable) connection?
- Are the IP Addresses of the PC and code reader set correctly?  
→ Refer to step 4 for setting the IP address of the PC.

For other measures that can be taken, please refer to *What should I do if I can't connect to WebLinkHH?* in Q&A – Section 8 of the *V460-H Industrial Handheld DPM Reader User Manual* (Cat. No. Z461).

- 8** The WebLinkHH screen appears.

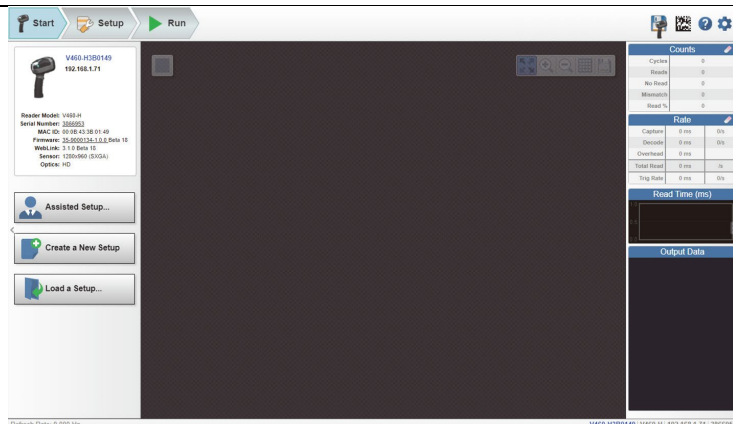



**9** Click on the gear icon on the upper right of the screen and select **Advanced**.

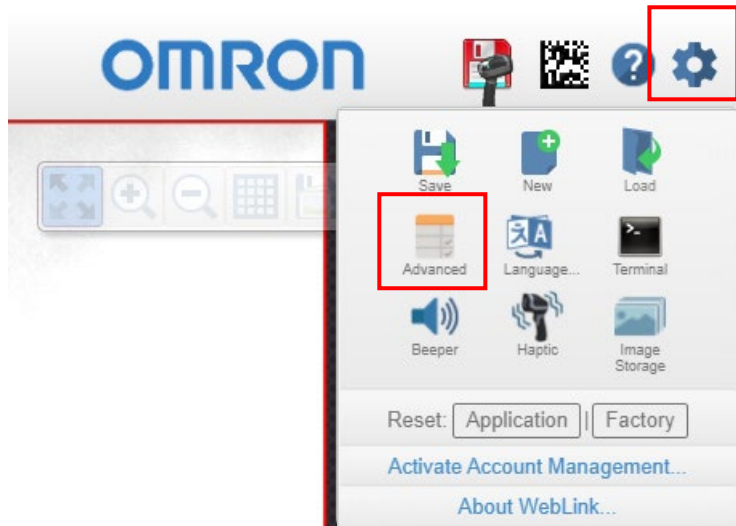

**10** The Advanced Settings Screen appears. Check the settings shown in the red frames.

EtherNet/IP connection is Enabled by default. However, to connect with the CJ Series, change the subnet mask to **255.255.255.0**.

If you need to change the IP address, for example when connecting multiple code readers, change the **IP Address** and subsequent settings as necessary.

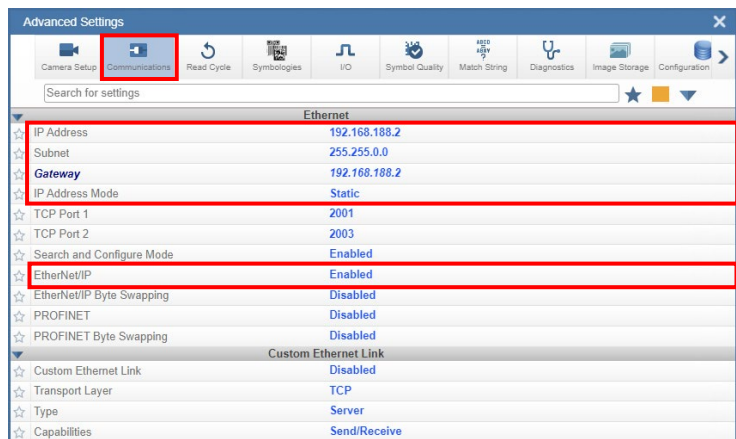

**11** Click on the icon shown in the red frame to save the settings to the code reader.

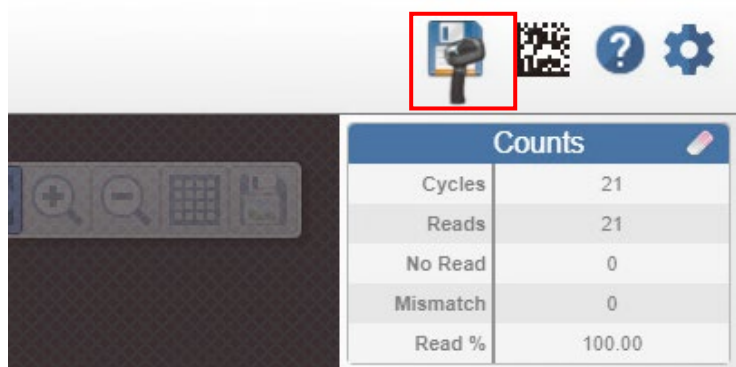

- 12** Finally, check the version number of the code reader. Click on the gear icon on the upper right of the screen and select **About WebLink**.

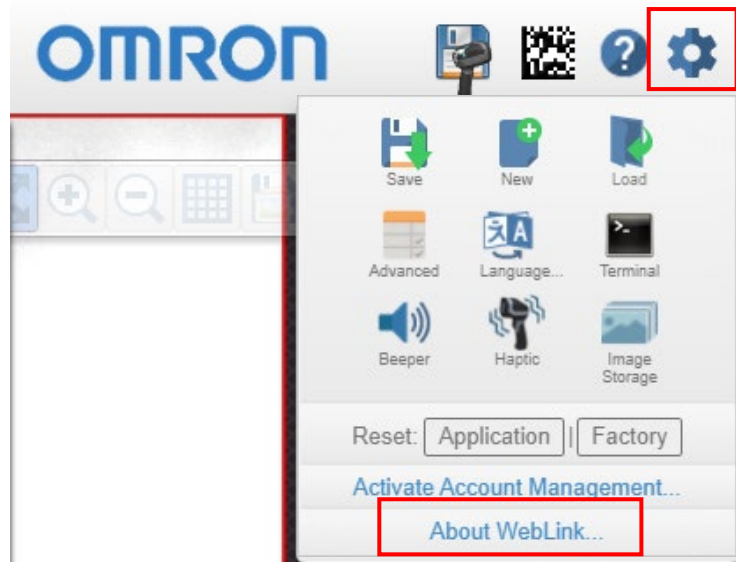

- 13** You can check the current version of the code reader in **About WebLinkHH**.

Update the code reader to the latest version as needed.



## 7.3. PLC Setup

Set up the PLC.

### 7.3.1. Setting the Hardware

Set up the physical switches on the EtherNet/IP Unit and perform wiring for network connection.



#### Precautions for Correct Use

Turn OFF the power supply before setting the hardware.

- 1** Check that the power supplies to the PLC, code reader, and switching hub are OFF.

\* If the power supplies are ON, you may not be able to proceed with the subsequent steps of the procedure.
- 2** Check the position of the physical switches on the front of the EtherNet/IP Unit as shown in the figure on the right.

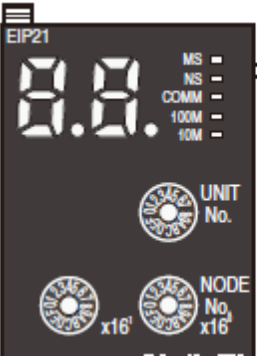

← LED Indicators

← Unit number setting switch

← Node address setting switches
- 3** Set the Unit No. switch to “0”.

**Setting the Unit Number**

The unit number is used to identify individual CPU Bus Units when more than one CPU Bus Unit is mounted to the same PLC. Use a small screwdriver to make the setting, taking care not to damage the rotary switch. The unit number is factory-set to 0.

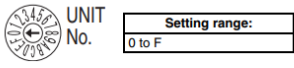

UNIT No.	Setting range:
0	0 to F
- 4** Set the Node address switches to the default values as follows.

NODE No. X16<sup>1</sup>: 0

NODE No. X16<sup>0</sup>: 1

\* Set the IP Address to **192.168.188.1**.

\* By default, the first three octets are fixed to “192.168.188”. The value set by the Node address switches determines the fourth octet of the node’s IP address.

**Setting the Node Address**

With the FINS communications service, when there are multiple EtherNet/IP Units connected to the Ethernet network, the EtherNet/IP Units are identified by node addresses. Use the node address switches to set the node address between 01 and FE hexadecimal (1 to 254 decimal). Do not set a number that has already been set for another node on the same network.

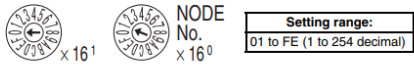

NODE No. x16 <sup>0</sup>	Setting range:
1	01 to FE (1 to 254 decimal)

\* The left switch sets the sixteens digit (most significant digit) and the right switch sets the ones digit (least significant digit). The node address is factory-set to 01.
- 5** Connect a LAN cable to the EtherNet/IP Port and a USB cable to the USB Port of the PLC, and connect a PC and a switching hub to the PLC as shown in 5.2. *Device Configuration*.

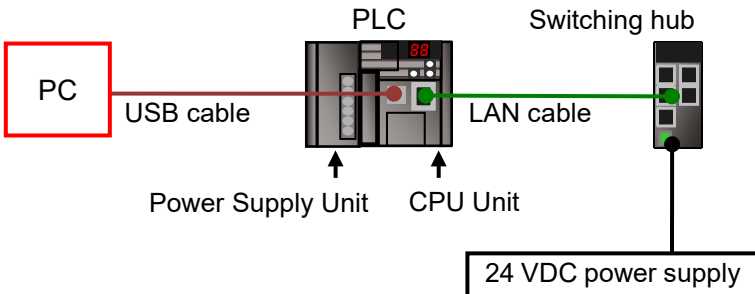



- 6** Turn ON the power supplies to the PLC, code reader, and switching hub.
- 7** The set IP address is displayed on the 7-segment LED display in sequence from the right to the left. After that, the lower eight bits of the IP address are displayed in hexadecimal during normal operation.

7.3.2. Starting the CX-Programmer and Going Online with the PLC

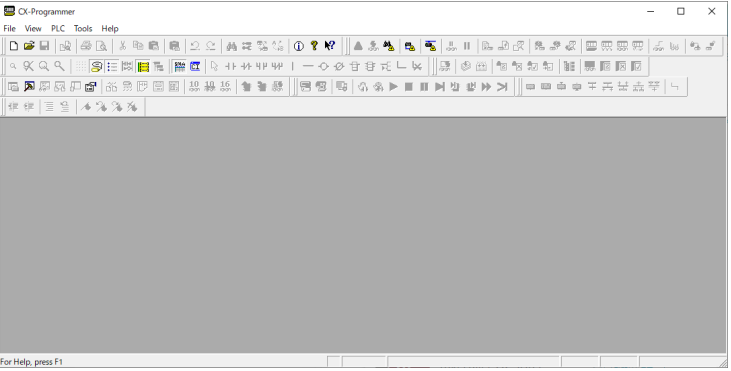
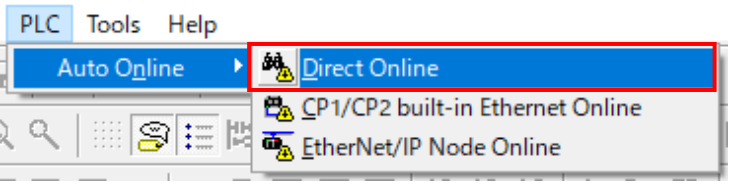
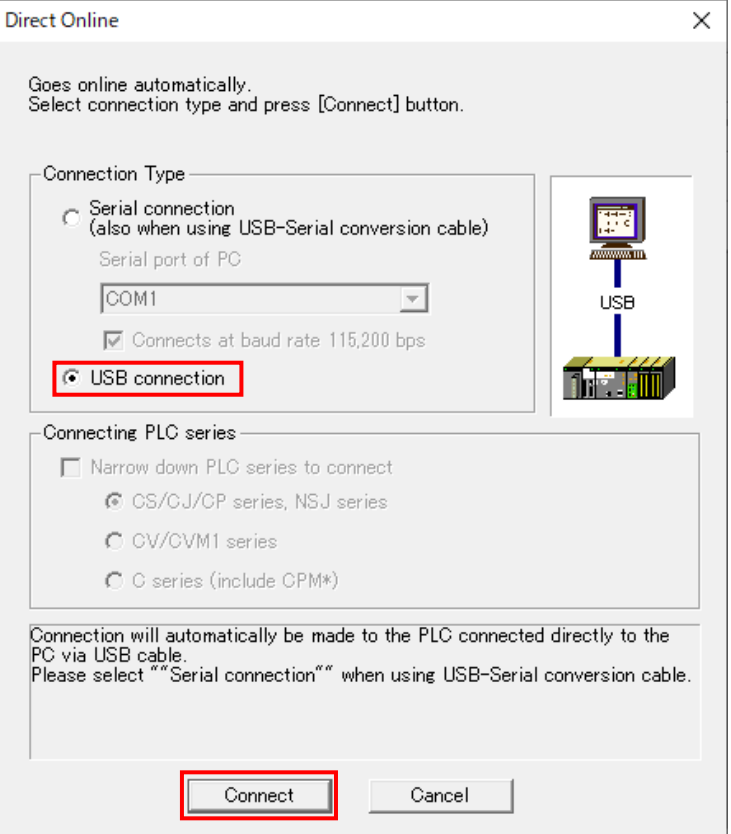
Start the CX-Programmer and go online with the PLC.

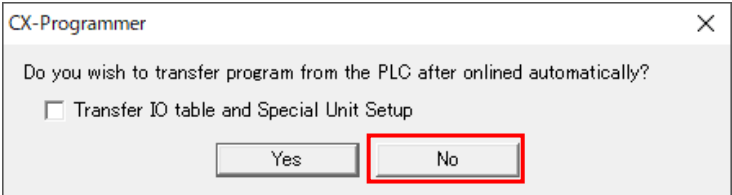
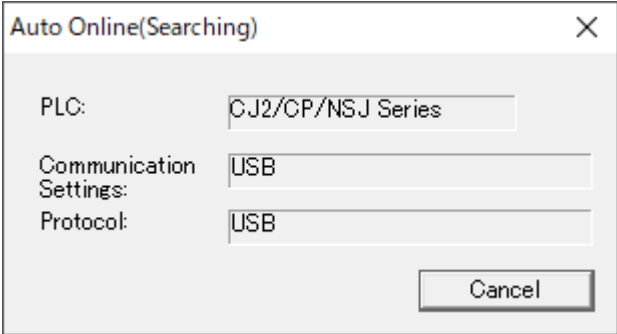
Install the CX-One and USB driver on the PC beforehand.

<p><b>1</b> Start the CX-Programmer.</p> <p>* If a user account control dialog box is displayed at startup, select the option to start.</p>	
<p><b>2</b> The CX-Programmer starts.</p>	
<p><b>3</b> Select <b>Auto Online – Direct Online</b> from the <b>PLC</b> Menu.</p>	
<p><b>4</b> The <b>Direct Online</b> Dialog Box is displayed. In <b>Connection Type</b>, select <b>USB connection</b>. Click on <b>Connect</b>.</p>	

<p><b>5</b> A confirmation dialog box as shown in the figure on the right appears. Read the information and click <b>No</b>.</p>	
<p><b>6</b> A dialog box as shown in the figure on the right appears and auto connection is performed.</p>	
<p><b>7</b> Confirm that the CX-Programmer is online with the PLC.</p> <p>* The CX-Programmer is online if the  icon appears to be depressed.</p>	



### Note

If you cannot go online with the PLC, check the physical cable connections, etc.  
 If the physical cable connections are correct, return to step 1 and follow the setup procedures again.  
 For details, refer to the *CX-Programmer Operation Manual* (Cat. No. W446).



### Note

Some of the dialog boxes shown in the following procedures may not be displayed depending on the environment settings of the CX-Programmer.  
 For details on the environment settings of the CX-Programmer, refer to the *CX-Programmer Operation Manual* (Cat. No. W446).  
 This document assumes that the check box for **Confirm all operations affecting the PLC** is selected.

7.3.3. Creating the I/O Table and Setting the IP Address

Create the I/O table for the PLC and set the IP address.

**1** If the PLC Operating Mode is set to either **Run** or **Monitor**, follow steps (1) to (3) to change it to **Program**.

(1) In the CX-Programmer, select **Operating Mode – Program** from the **PLC** Menu.

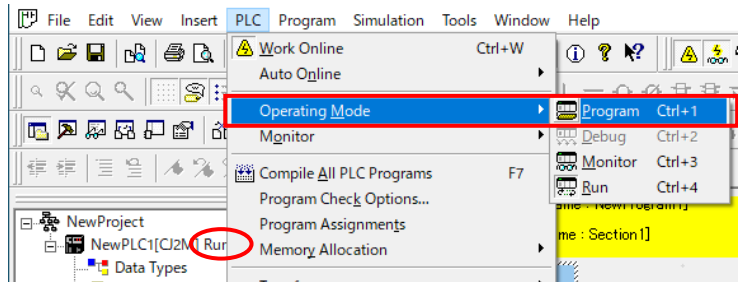

(2) A confirmation dialog box as shown in the figure on the right appears. Confirm that there is no problem and click **Yes**.

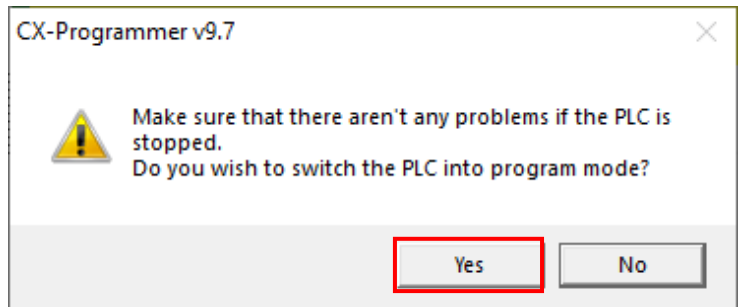

\* For information on how the dialog box is displayed, refer to *Note* on the previous page.

(3) Confirm that **Program Mode** is displayed to the right of the PLC model in the CX-Programmer's project workspace. (See the figure on the right.)

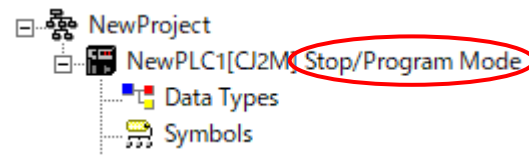

(Project Workspace)

**2** In the CX-Programmer, select **Edit – I/O Table and Unit Setup** from the **PLC** Menu.

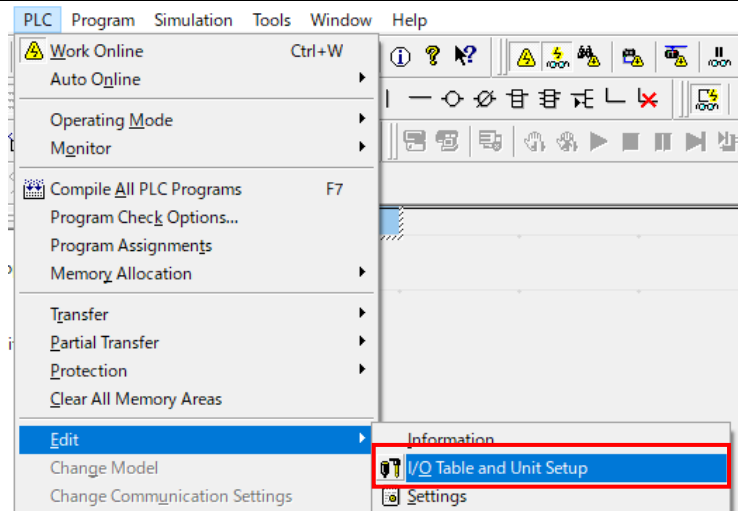

The **PLC IO Table** Window is displayed.

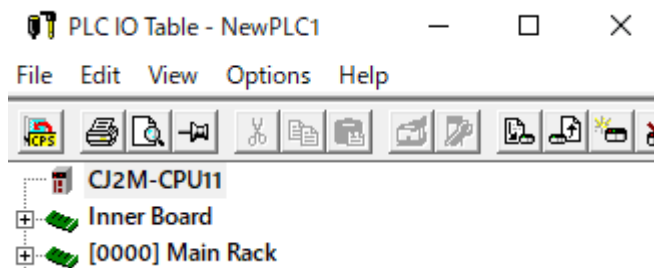



### Precautions for Correct Use

Performing I/O Table creation and transfer in step 3 and later resets the PLC. Confirm the system safety before you perform I/O Table creation and transfer.

- 3** In the **PLC IO Table** Window, select **Create** from the **Options** Menu.

A confirmation dialog box as shown in the figure on the right appears. Confirm that there is no problem and click **Yes**.

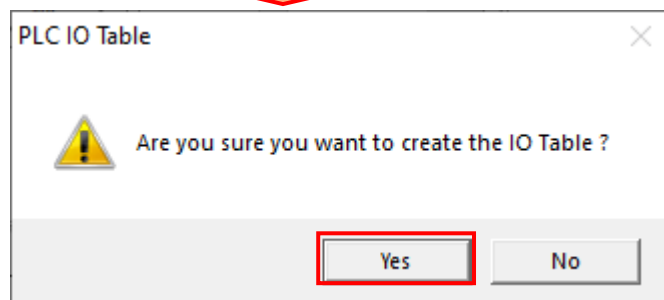
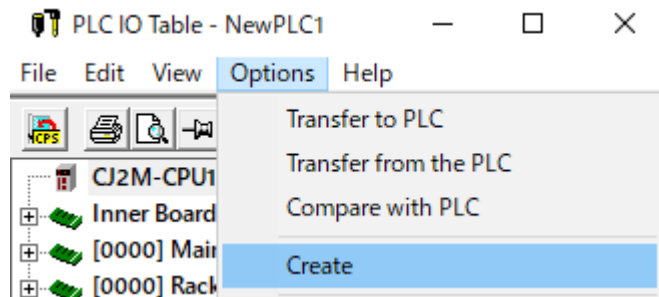

Another confirmation dialog box as shown in the figure on the right appears. Confirm that there is no problem and click **Yes**.

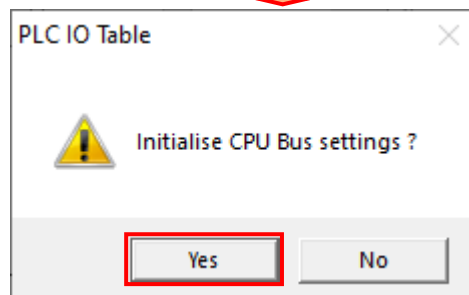

**4** The **Transfer from PLC** Dialog Box is displayed. Select the check boxes for **IO Table** and **SIO Unit Parameters** and click **Transfer**.

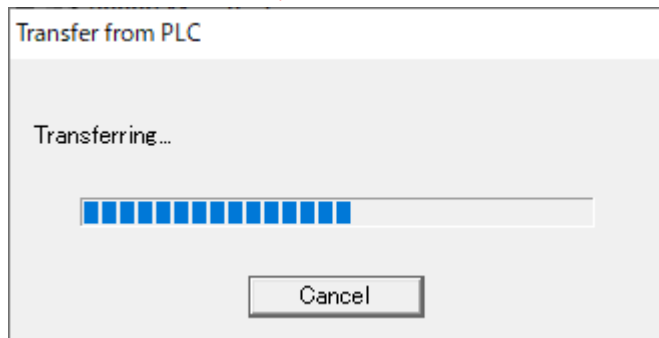
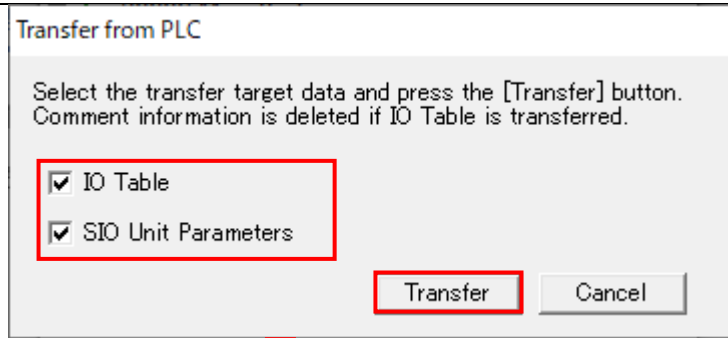

When the transfer is complete, the **Transfer Results** Dialog Box appears.

Check the messages in this dialog box to confirm that the transfer process is successfully completed.

The figure on the right shows **Transfer Success: 1 Unit** and **Transfer Unsuccessful: 0 Unit**, which means I/O table creation is successfully completed.

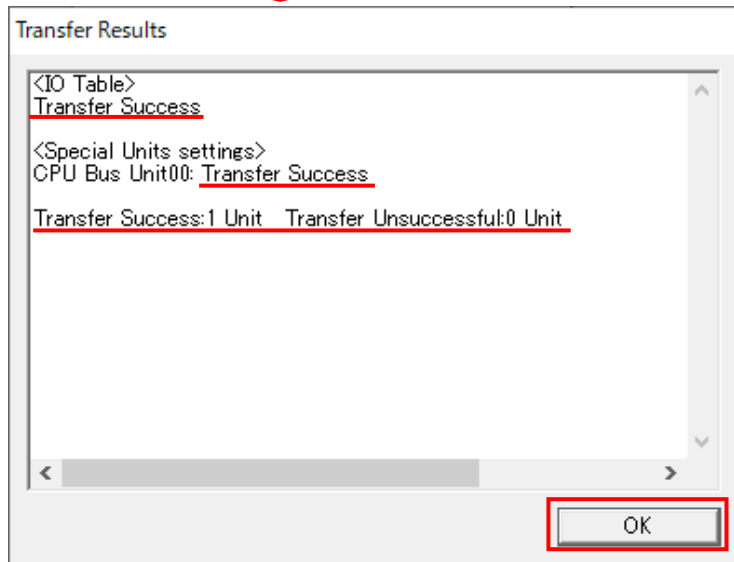

Click **OK**.

**5** In the **PLC IO Table** Window, double-click **[0000] Main Rack** to open the tree.

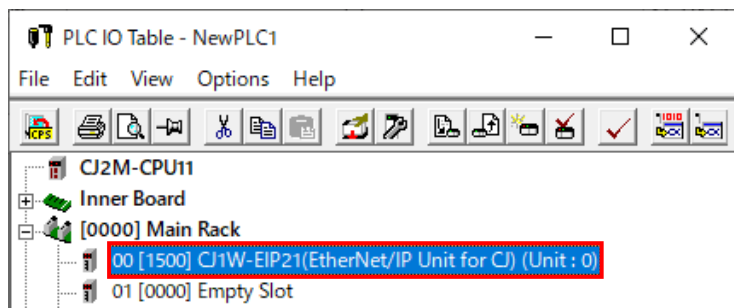



**6** Right-click on **00 [1500] CJ1W-ETN21(ETN21Mode)** and select **Unit Setup** from the menu.

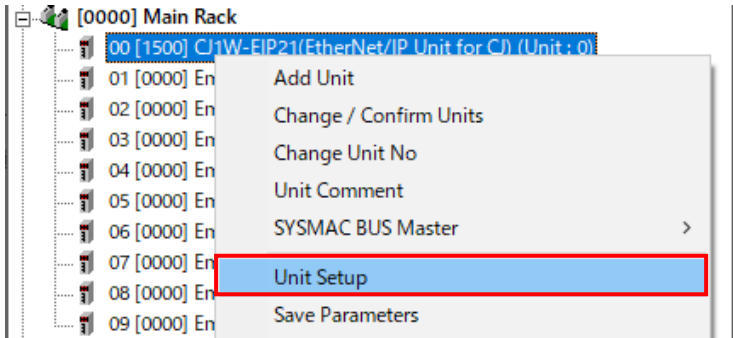

**7** The **Edit Parameters** Dialog Box is displayed. Select the **TCP/IP** Tab Page.

In **IP Address**, set the items as follows.

- Use the following address:  
Selected
- IP Address: 192.168.188.1
- Subnet mask:  
255.255.255.0

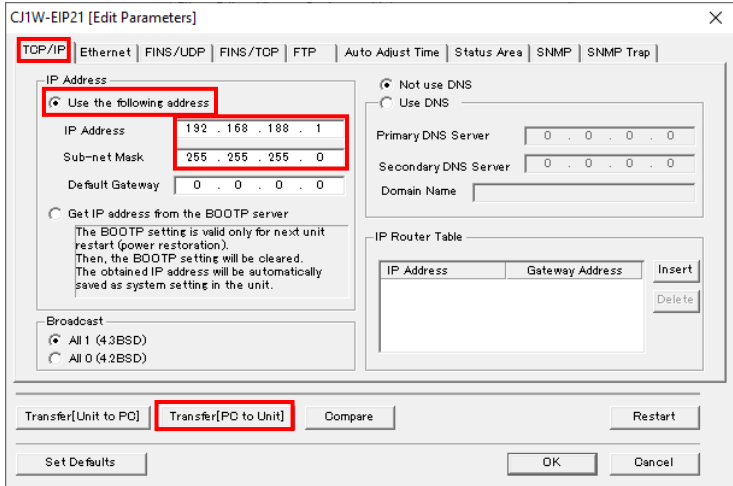

Click **Transfer [PC to Unit]**.

**8** A confirmation dialog box as shown in the figure on the right appears. Confirm that there is no problem and click **Yes**.

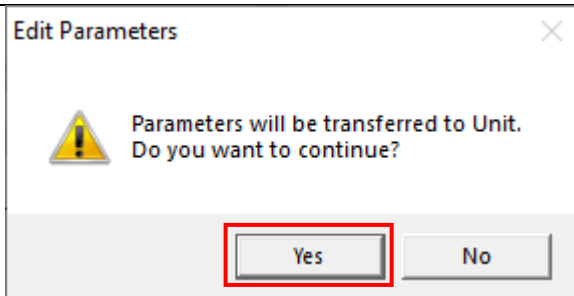

Confirm that **Transfer successful** is displayed and click **Close**.

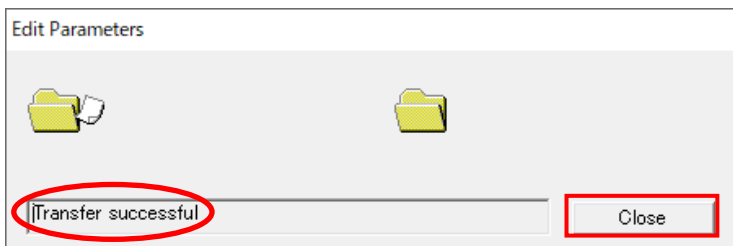

**9** A confirmation dialog box as shown in the figure on the right appears. Read the information and click **Yes**.

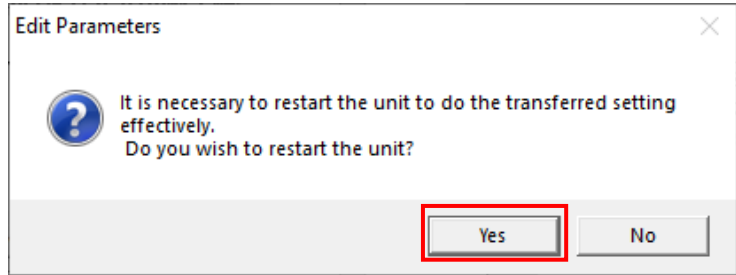

After you restart the unit, another dialog box as shown in the figure on the right appears. Read the information and click **OK**.

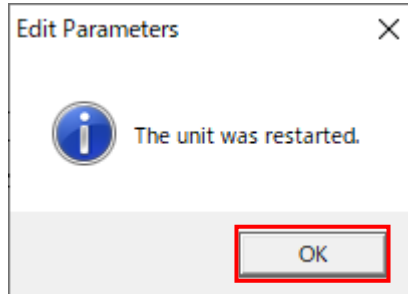

**10** Click **Compare** to confirm that the IP address is correctly changed.

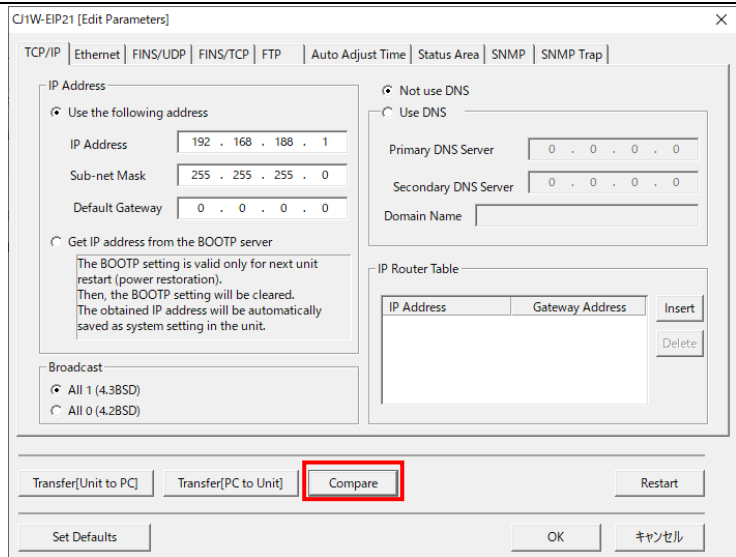

**11** Confirm that **Compare successful** is displayed and click **Close**.

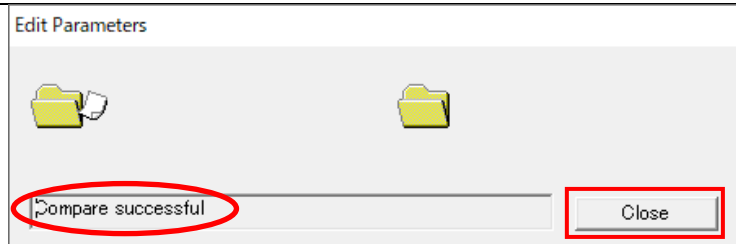

**12** Click **OK** in the **Edit Parameters** Dialog Box.

CJ1W-EIP21 [Edit Parameters]

TCP/IP | Ethernet | FINS/UDP | FINS/TCP | FTP | Auto Adjust Time | Status Area | SNMP | SNMP Trap

IP Address

Use the following address

IP Address: 192 . 168 . 188 . 1

Sub-net Mask: 255 . 255 . 255 . 0

Default Gateway: 0 . 0 . 0 . 0

Get IP address from the BOOTP server

The BOOTP setting is valid only for next unit restart (power restoration). Then, the BOOTP setting will be cleared. The obtained IP address will be automatically saved as system setting in the unit.

Broadcast

All 1 (4.3BSD)

All 0 (4.2BSD)

Not use DNS

Use DNS

Primary DNS Server: 0 . 0 . 0 . 0

Secondary DNS Server: 0 . 0 . 0 . 0

Domain Name:

IP Router Table

IP Address	Gateway Address	
		Insert
		Delete

Transfer[Unit to PC] | Transfer[PC to Unit] | Compare | Restart

Set Defaults | **OK** | キャンセル

## 7.4. Network Setup

Set up the EtherNet/IP Tag data links.

### 7.4.1. Starting the Network Configurator and Going Online with the PLC

Start the Network Configurator and go online with the PLC.

**1** In the **PLC IO Table Window**, right-click on **CJ2M-EIP21** and select **Start Special Application – Start with Settings Inherited** from the menu.

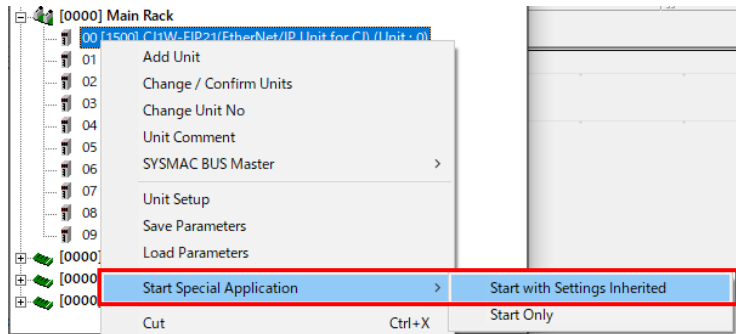

The **Select Special Application** Dialog Box is displayed. Select **Network Configurator** and click **OK**.

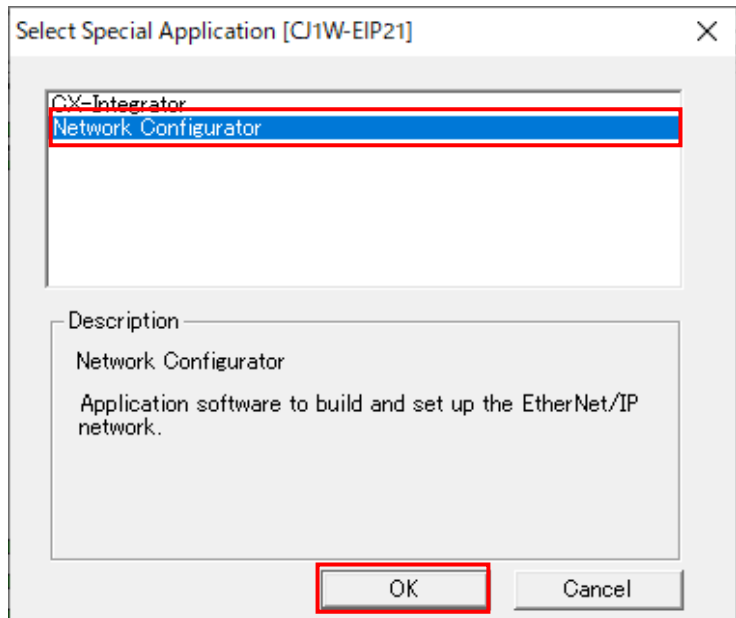

**2** The Network Configurator starts.

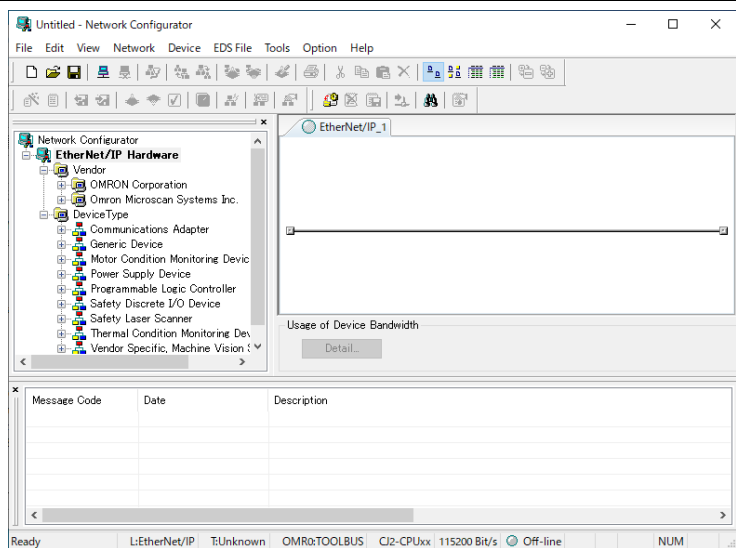



**Precautions for Correct Use**

Before performing the following steps, confirm that the LAN cable is connected securely. If it is not connected, first turn OFF the power supply to the device and then connect the LAN cable.

<p><b>3</b> Select <b>Select Interface – CJ2 USB/Serial Port</b> from the <b>Option</b> Menu.</p>	
<p><b>4</b> Select <b>Connect</b> from the <b>Network</b> Menu.</p>	
<p><b>5</b> The <b>Setup Interface</b> Dialog Box appears. Confirm that the settings are as follows.</p> <p>Port Type: USB          Port: OMR0          Baud Rate: 115200 Bit/s</p> <p>Click <b>OK</b>.</p>	
<p><b>6</b> The <b>Select Connect Network Port</b> Dialog Box appears. In the tree, select <b>Back Plane – CJ1W-EIP21(CJ2) – TCP:2</b>.</p> <p>Click <b>OK</b>.</p>	
<p><b>7</b> The <b>Select Connected Network</b> Dialog Box appears. Confirm the contents and click <b>OK</b>.</p>	

- 8** If the Network Configurator is successfully connected online, the dot next to the network name turns blue.

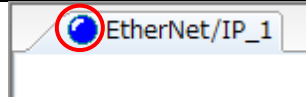

### Note

If you cannot go online with the PLC, check the physical cable connections, etc.  
If the physical cable connections are correct, return to step 3 and follow the setup procedures again.

For details, refer to *6-2-9 Connecting the Network Configurator to the Network* in *Section 6 Tag Data Link Functions* of the *EtherNet/IP™ Units Operation Manual* (Cat. No. W465).

7.4.2. Installing the EDS File

Install the EDS file for V460-H.

The EDS file can be downloaded from the OMRON web page.

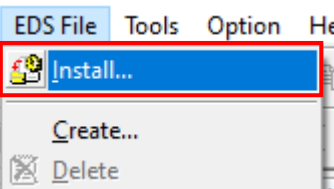
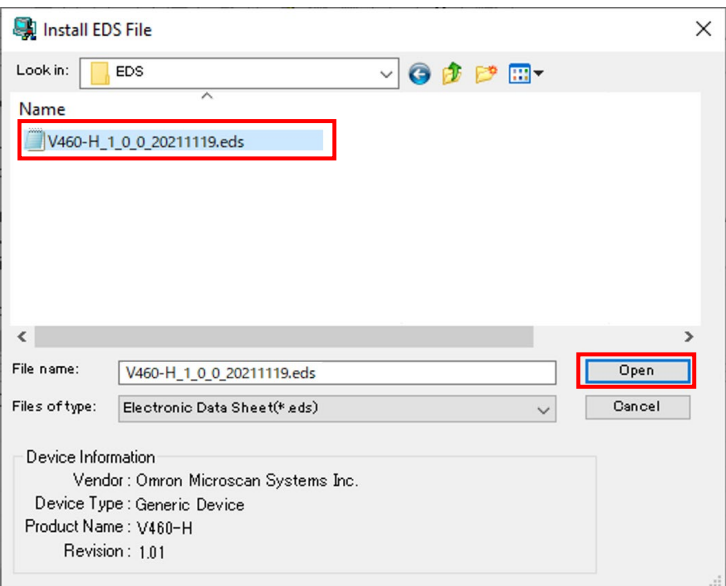
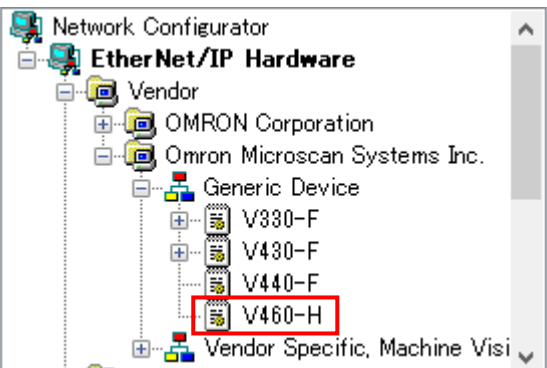
<p><b>1</b> Select <b>Install</b> from the <b>EDS File</b> Menu.</p>	
<p><b>2</b> The dialog shown in the figure on the right appears. Select the downloaded EDS file and click <b>Open</b>.</p>	
<p><b>3</b> Confirm that <b>V460-H</b> is added.</p>	

### 7.4.3. Uploading the Network Configuration

Upload the configuration for devices on the network.

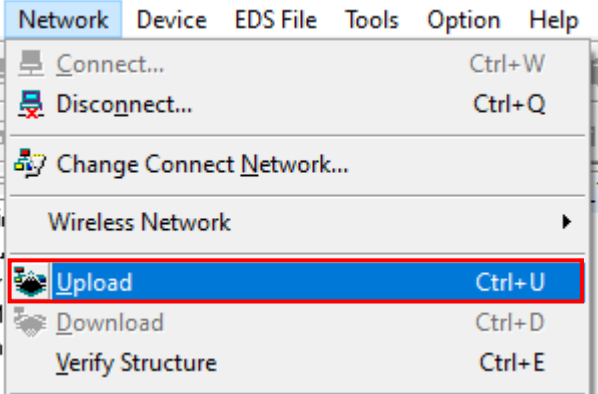
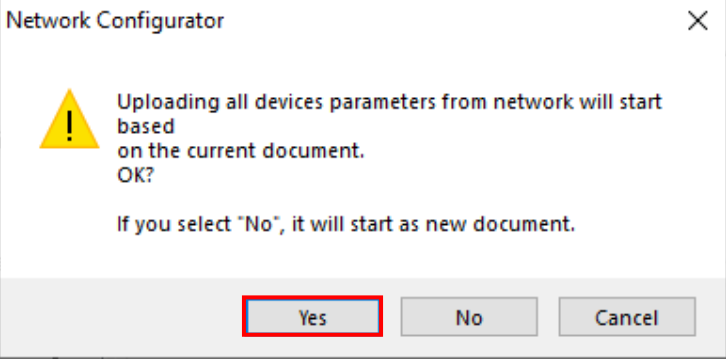
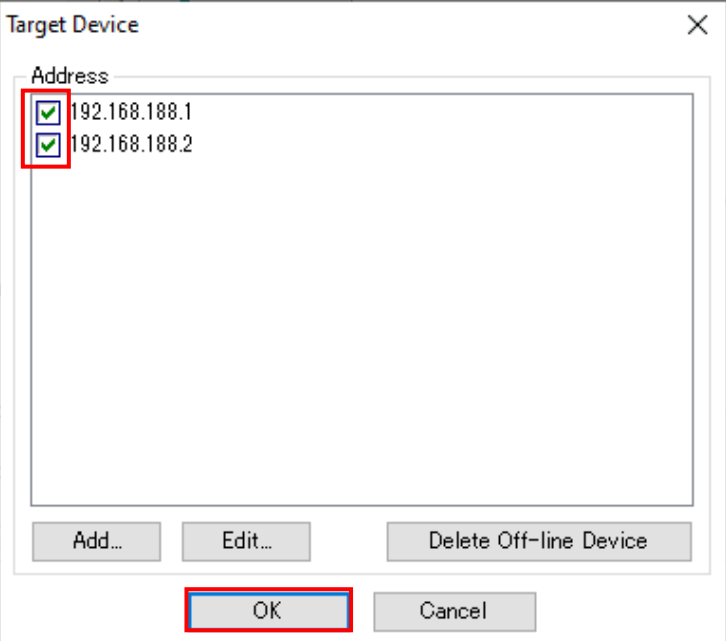
<p><b>1</b> Select <b>Upload</b> from the <b>Network</b> Menu to upload parameters of the devices on the network.</p>	
<p><b>2</b> A confirmation dialog box as shown in the figure on the right appears. Confirm that there is no problem and click <b>Yes</b>.</p>	
<p><b>3</b> In the <b>Target Device</b> Dialog Box, select the check boxes for <b>192.168.188.1</b> and <b>192.168.188.2</b>.</p> <p>Click <b>OK</b>.</p> <p>* If <b>192.168.188.1</b> and <b>192.168.188.2</b> are not displayed in the dialog box, click <b>Add</b> to add the IP addresses.</p> <p>* The addresses displayed in the dialog box vary depending on the use of the Network Configurator.</p>	



- 4** When the upload of the device parameters is complete, a confirmation dialog box as shown in the figure on the right appears. Read the information and click **OK**.

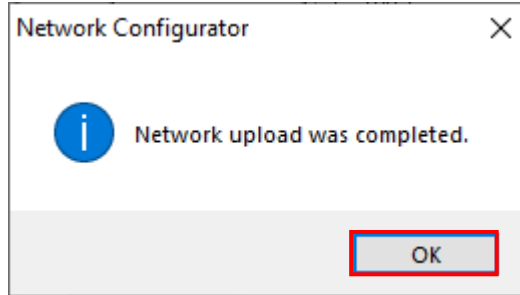

- 5** In the **Network Window** after the upload, confirm that the IP address setting for each node is updated as follows.

Node 1 IP Address:

192.168.188.1

Node 2 IP Address:

192.168.188.2

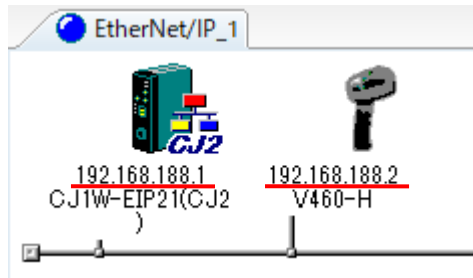

\* The code reader icon is changed to **V460-H**.

**7.4.4. Setting the Tags**

Register the tags for the Send area and Receive area.

Here, the procedure for setting the Receive area and Send area for the target node are described in this order.

- 1** In the Network Configurator, right-click on the Node 1 device in the **Network Window** and select **Parameter – Edit**.

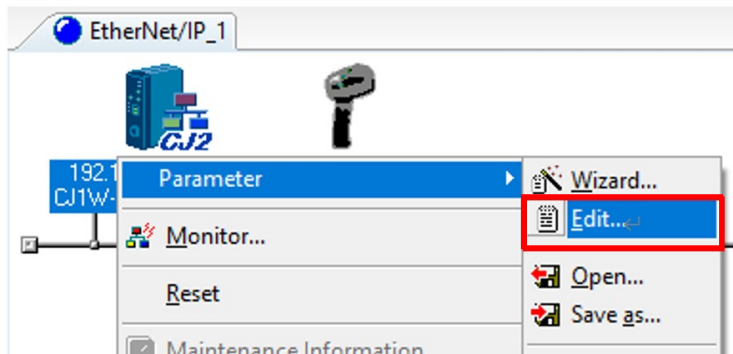

- 2** In The **Edit Device Parameters** Dialog Box, select the **Tag Sets** Tab.

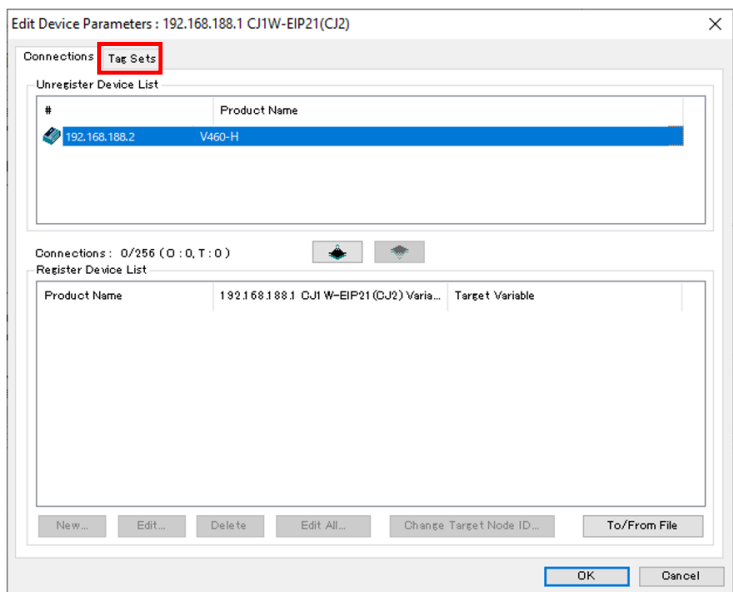

- 3** The **Tag Sets** Tab Page is displayed. Select the **In - Consume** Tab and click **Edit Tags**.

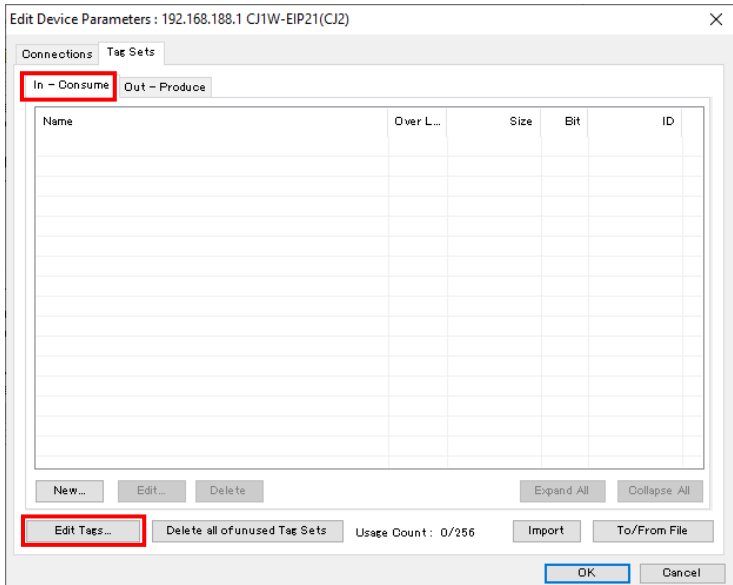

**4** The **Edit Tags** Dialog Box is displayed. Select the **In - Consume** Tab and click **New**. Here, register the tags for the Receive area where Node 1 receives input data (Node 2 → Node 1).

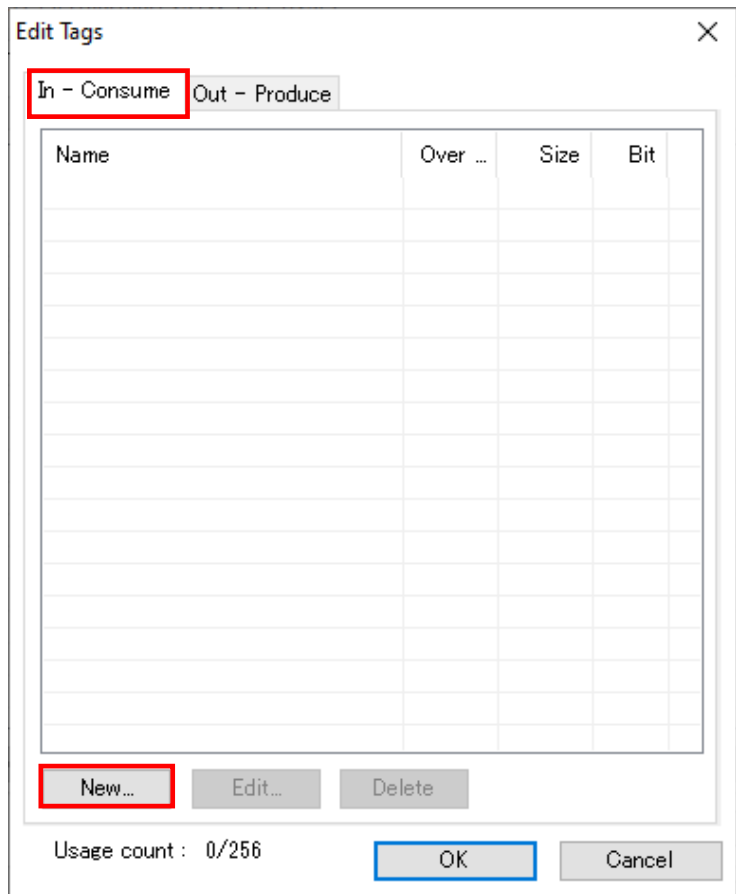

**5** The **Edit Tag** Dialog Box is displayed. Enter parameter values as follows.  
 Name: D10000 (Start address of input data to Node 1)  
 Size: 500 (Byte)

After entering the above values, click **Regist**.

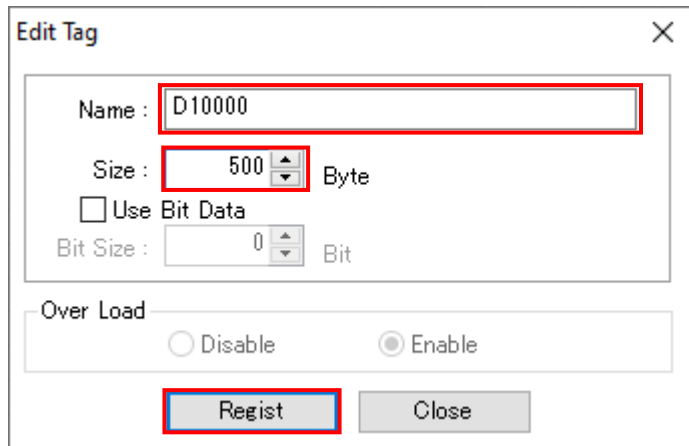

**6** The **Edit Tag** Dialog Box is displayed again. Click **Close**.



- 7** Click the **Out – Produce** Tab and click **New**.  
Here, register the tags for the Send area where Node 1 sends output data (Node 1 → Node 2).

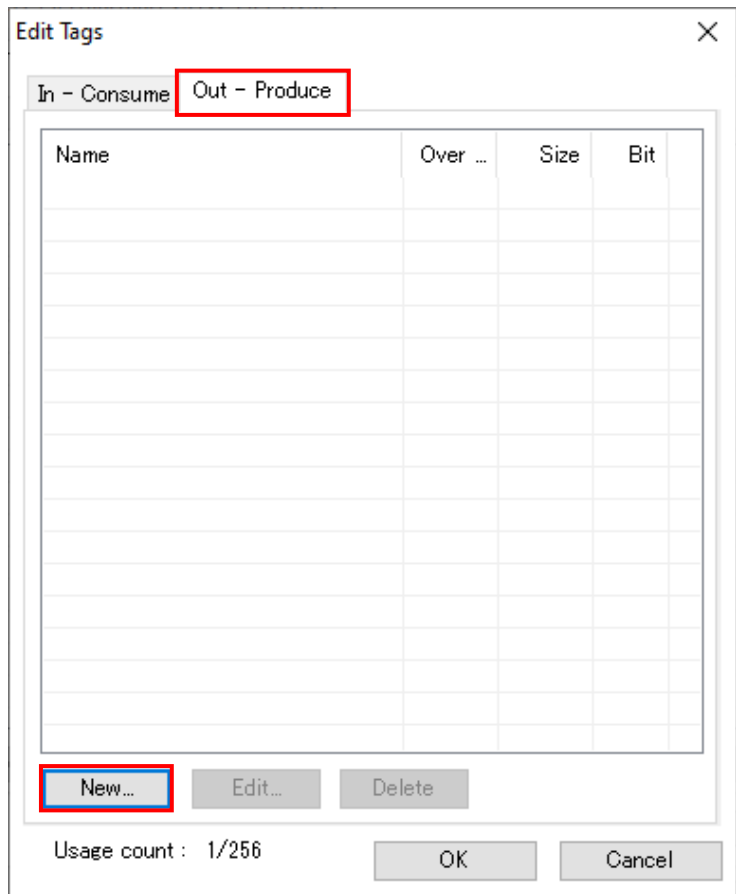

- 8** The **Edit Tag** Dialog Box is displayed. Enter parameter values as follows.  
  
Name: D11000 (Start address of output data from Node 1)  
Size: 4 (Byte)

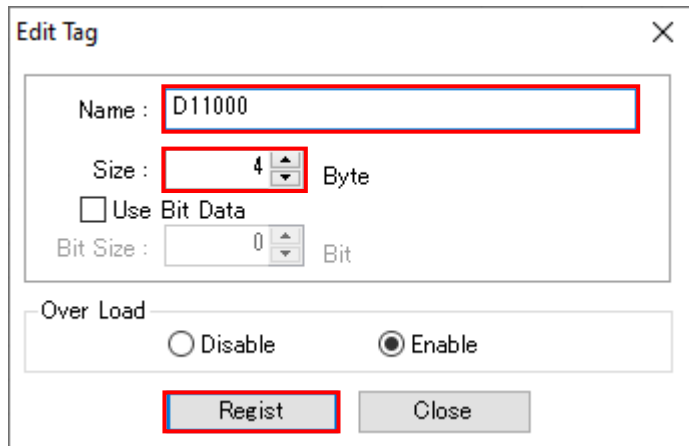

After entering the above values, click **Regist**.

- 9** The **Edit Tag** Dialog Box is displayed again. Click **Close**.



**10** After registering the tags, click **OK** in the **Edit Tags** Dialog Box.

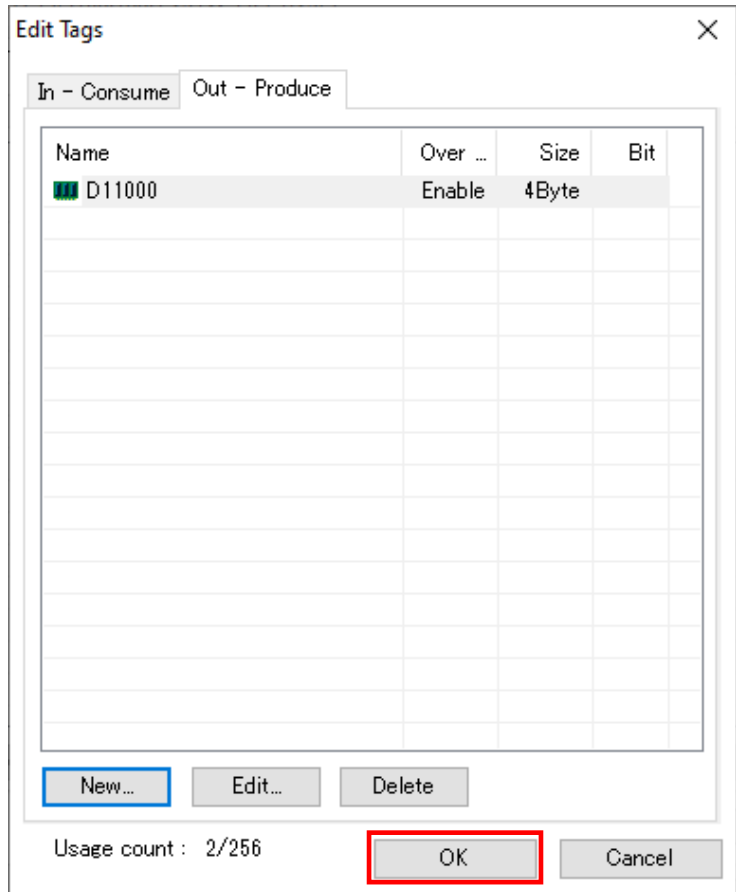

**11** A confirmation dialog box as shown in the figure on the right appears. Confirm that there is no problem and click **Yes**.

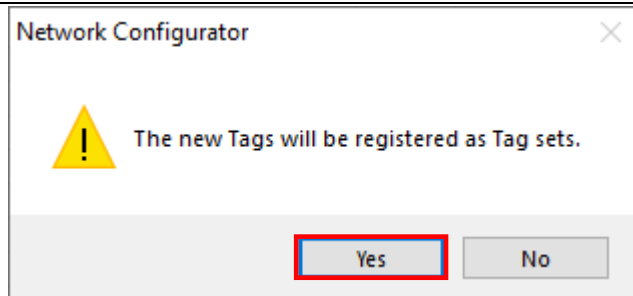

**12** You are returned to the **Edit Device Parameters** Dialog Box. Select the **Connections** Tab.

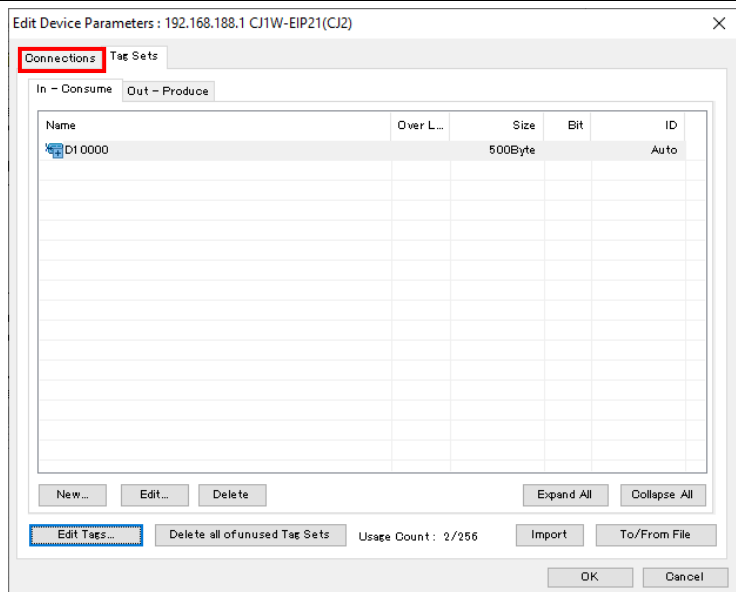

7.4.5. Setting Up the Connections

For the registered tags, configure the settings to associate the tags for the target device (side on which connections are to be established) with the tags for the originator (side on which you want to establish connections).

- 1 Select **192.168.188.2** in the **Unregister Device List** and click ↓ as shown in the figure.

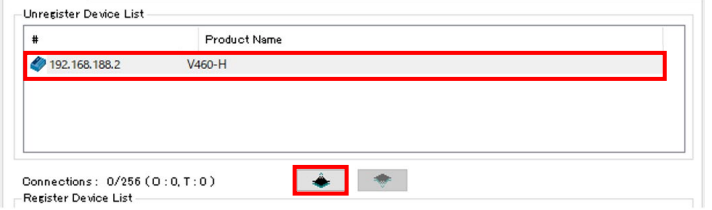

- 2 **192.168.188.2** is registered in the **Register Device List**. With **192.168.188.2** selected, click **New**.

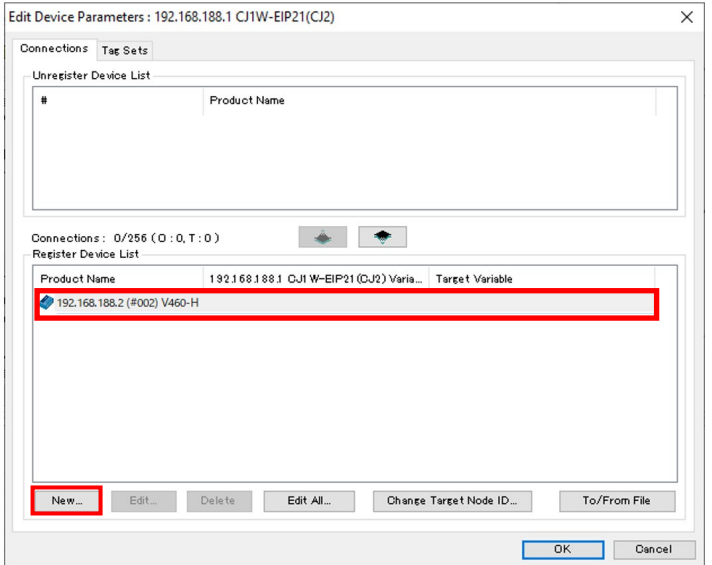

- 3 The **Edit Connection Dialog Box** is displayed. Select **Input 1 Decode** from the **Connection I/O Type** pull-down menu. Similarly, set the values shown in the following table in the **Originator Device** and **Target Device** settings fields.

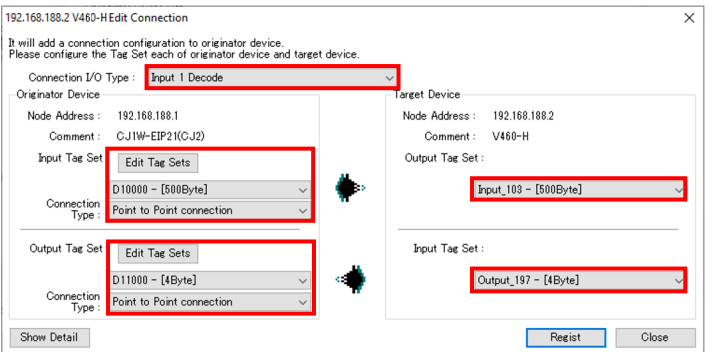

■ Settings in Edit Connection Dialog Box

Connection item		Setting
Connection I/O Type		Input 1 Decode
Originator Device	Input Tag Set	D10000 - [500 Byte]
	Connection Type	Point to Point connection
	Output Tag Set	D11000 - [4 Byte]
	Connection Type	Point to Point connection
Target Device	Output Tag Set	Input_103 - [500 Byte]
	Input Tag Set	Output_197 - [4 Byte]
Detail Parameter	Packet Interval (RPI)	10.0 ms
	Timeout	Packet Interval (RPI) x 32

**4** Confirm that the settings are correct, and click **Register**.

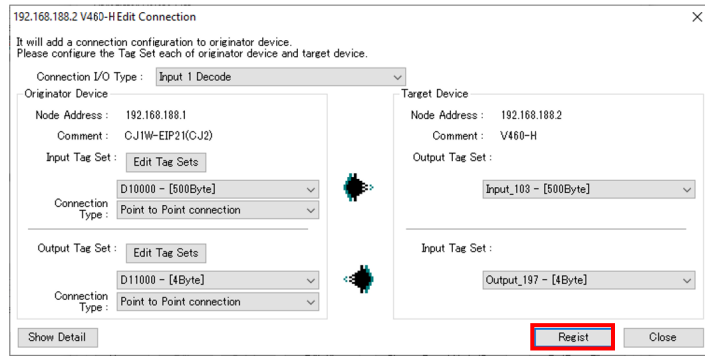

**5** The **Edit Connection** Dialog Box is displayed again. Click **Close**.

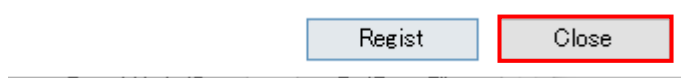

**6** You are returned to the **Edit Device Parameters** Dialog Box. Click **OK**.

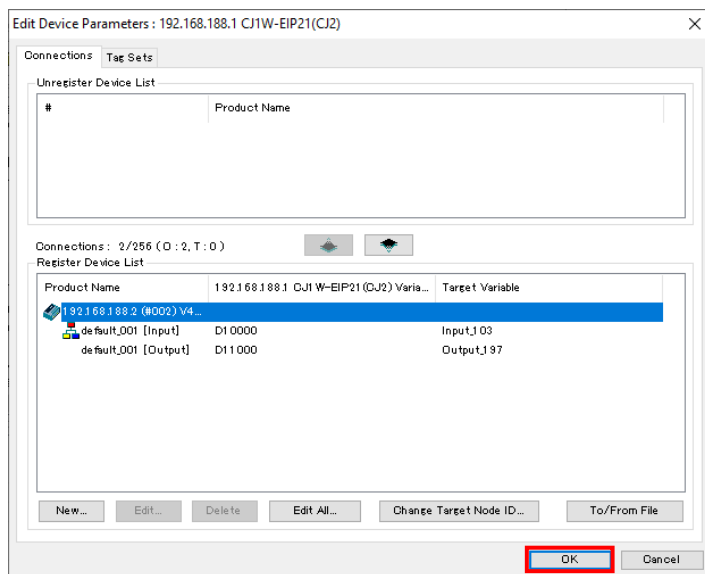

**7** When connection assignment is completed, the registered node address is displayed under the device icon for Node 2 in the **Network Window**.

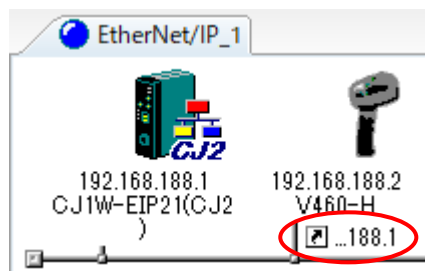

### 7.4.6. Transferring the Tag Data Link Parameters

Transfer the set tag data link parameters to the PLC.

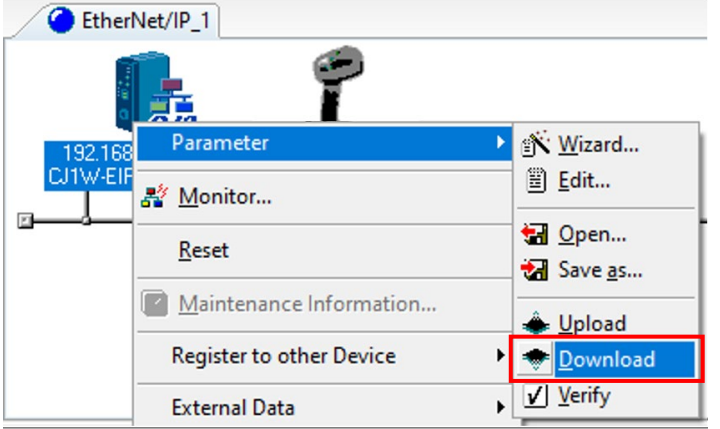
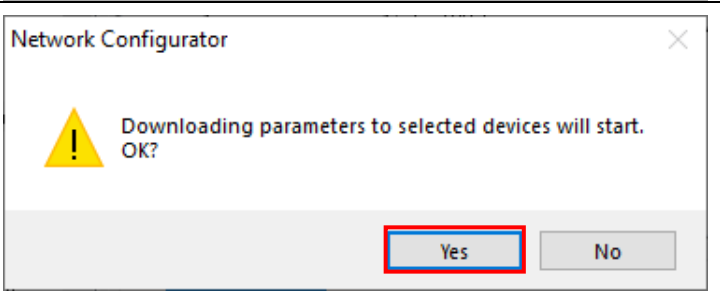
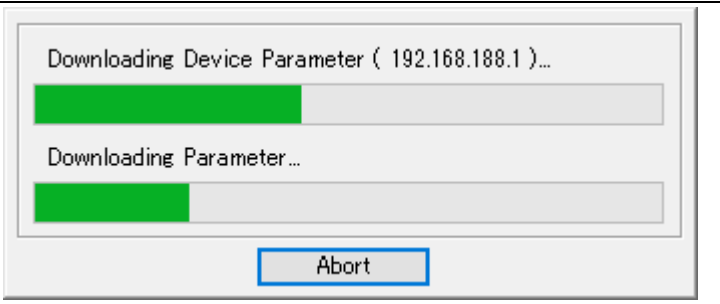
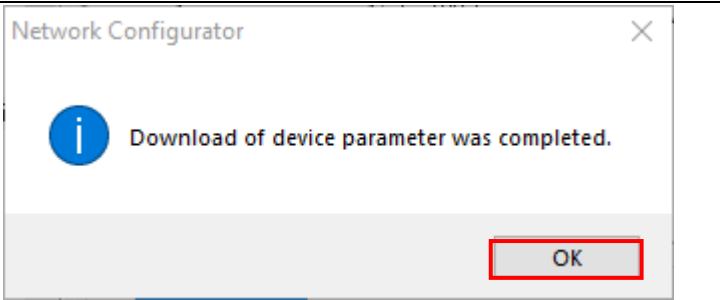
<p><b>1</b> Right-click on the Node 1 device in the <b>Network Window</b> and select <b>Parameter – Download</b>.</p>	
<p><b>2</b> A confirmation dialog box as shown in the figure on the right appears. Confirm that there is no problem and click <b>Yes</b>.</p>	
<p><b>3</b> The tag data link parameters are transferred from the Network Configurator Controller to the PLC.</p>	
<p><b>4</b> A confirmation dialog box as shown in the figure on the right appears. Read the information and click <b>OK</b>.</p>	



## 7.5. Checking the EtherNet/IP Communications

Check that the EtherNet/IP tag data links are operating normally.

### 7.5.1. Checking the Connection Status

Check the EtherNet/IP connection status and display the WebLinkHH screen.

- 1 Check the LED indicators on the PLC (EtherNet/IP Unit) to confirm that the EtherNet/IP tag data links are operating normally.

Below is the LED status in normal operation.

MS: Lit Green

NS: Lit Green

COMM: Lit Yellow

100M or 10M: Lit Yellow



- 2 Check the LED indicators on the code reader. Below is the LED status for V460 in normal operation. LED indicators on code reader: Lit Orange



- 3 In the Network Configurator, check the status information in the **Monitor Device** Dialog Box to confirm that the tag data links are operating normally.

Right-click on the Node 1 device icon in the **Network Window** and select **Monitor**.

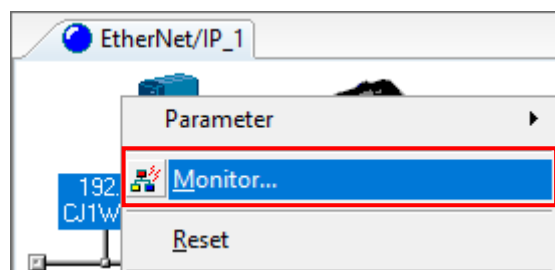

**4** The figure on the right shows the **Status 1** Tab Page of the **Monitor Device** Dialog Box.

If the same check boxes as shown in the right figure are selected, the tag data links are operating normally.

Click **Close**.

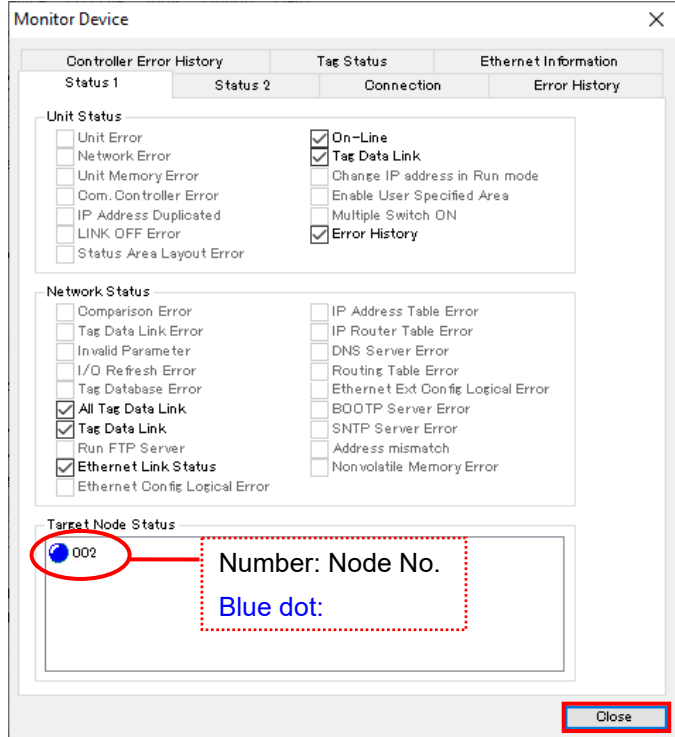

**5** Select **Disconnect** from the **Network** Menu to go offline.

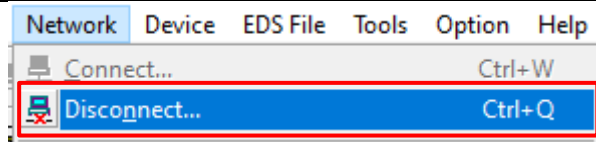

**6** The blue dot next to the network name changes to gray.

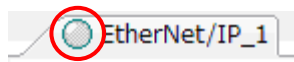

**7** Select **Exit** from the **File** Menu to exit the Network Configurator.

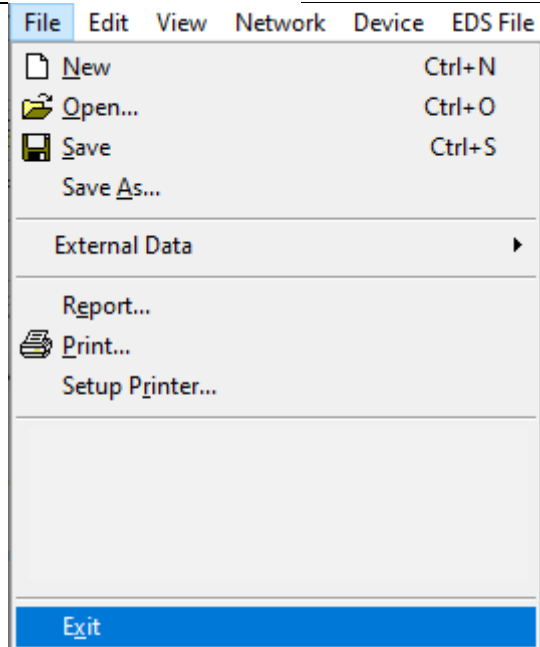

**8** Start your browser and enter *http://192.168.188.2*.

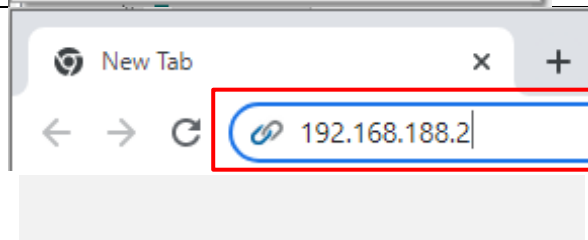

**9** The WebLinkHH startup screen appears.

If the WebLinkHH startup screen does not appear, please refer to page 17 of this manual or *What should I do if I can't connect to WebLinkHH?* in Q&A – Section 8 of the *V460-H Industrial Handheld DPM Reader User Manual* (Cat. No. Z461).



### 7.5.2. Checking the Sent and Received Data

Check that the correct data is sent and received.

**Caution**

If PLC memory is unintentionally changed by mistake during continuity/current value monitoring in the ladder section window or watch window, the connected devices may operate regardless of the operating mode of the CPU Unit. Sufficiently confirm safety before you perform continuity/current values monitoring in the ladder section window or watch window.

**1** Confirm that the operating mode of the PLC is **Program Mode**.

\* If not, refer to step 1 of the procedure in 7.3.3. *Creating the I/O Table and Setting the IP Address* and set it to PROGRAM mode.

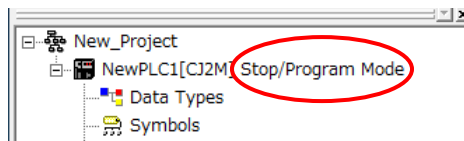

**2** This document uses the 2D code shown in the right figure as an example of reading. Set the code reader to the position where it can read the 2D code in the right figure.



**3** Select **Edit – Memory** from the PLC Menu.

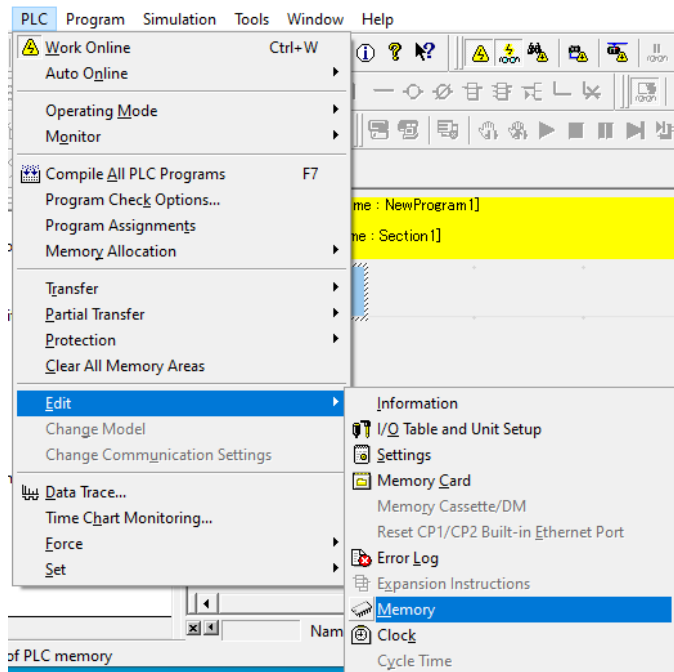

**4** The **PLC Memory** Window is displayed. Double-click **D** from the list in the left pane of the **PLC Memory** Window.

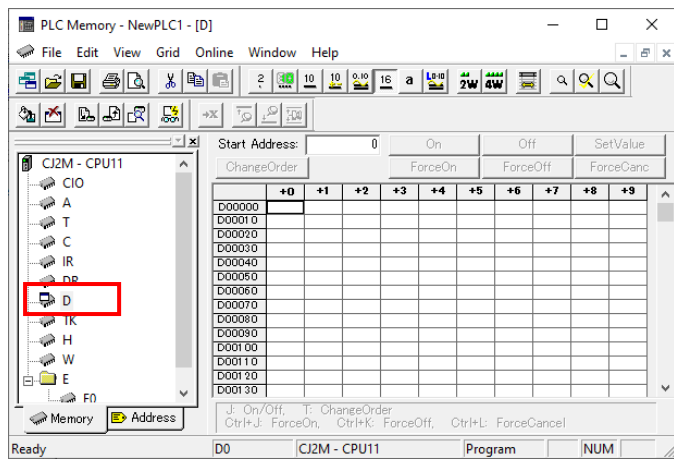

**5** Select **Display – Binary** from the **View** Menu.

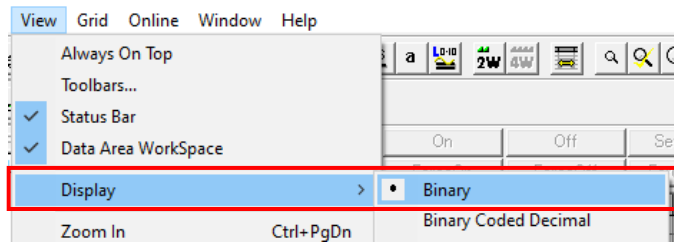

**6** Select **Monitor** from the **Online** Menu.

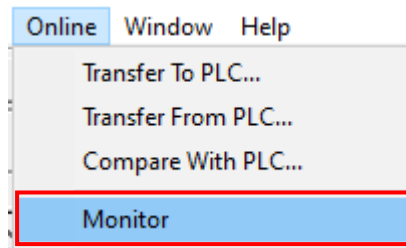

**7** The **Monitor Memory Areas** Dialog Box appears. Confirm that check box for **D** is selected and click **Monitor**.

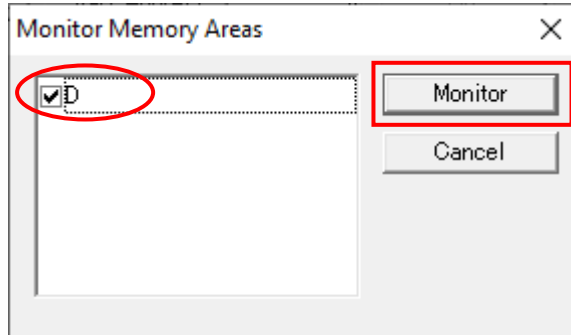

**8** In the **D** Window, enter **11000** in **Start Address**.

Confirm that the start address is changed to **D11000**.

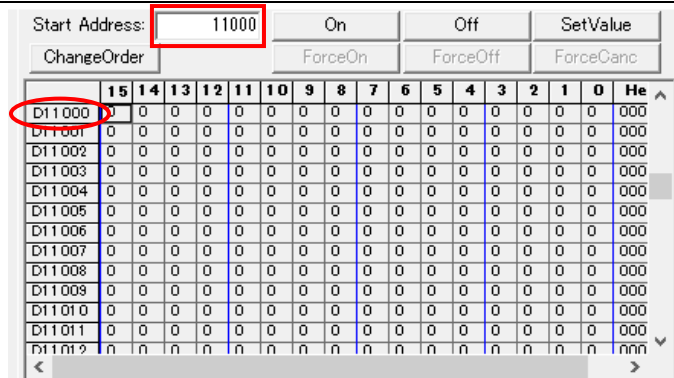

- 9** Select Bit 1 of **D11000** and click **On**.  
 (This changes the value to 1.)  
 After that, select Bit1 of **D11000**  
 again and click **Off**.

Start Address:	11000	<b>On</b>	Off	SetValue													
ChangeOrder		ForceOn	ForceOff	ForceCanc													
	15	14	13	12	11	10	9	8	7	6	5	4	3	2	1	0	Hex
D11000	0	0	0	0	0	0	0	0	0	0	0	0	0	0	<b>1</b>	0	000
D11001	0	0	0	0	0	0	0	0	0	0	0	0	0	0	0	0	000
D11002	0	0	0	0	0	0	0	0	0	0	0	0	0	0	0	0	000
D11003	0	0	0	0	0	0	0	0	0	0	0	0	0	0	0	0	000

\* The first bit of **D11000** corresponds to the **Trigger** bit of the Output Assembly. Setting it to 1 to enable trigger input.

- 10** The result of the Read operation is reflected in the WebLinkHH screen.

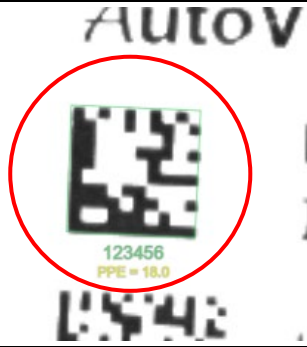

- 11** In the **D** Window, enter **10000** in **Start Address**.  
 Confirm that the start address is changed to **D10000**.

Start Address:	10000	On	Off	SetValue													
ChangeOrder		ForceOn	ForceOff	ForceCanc													
	15	14	13	12	11	10	9	8	7	6	5	4	3	2	1	0	Hex
<b>D10000</b>	0	0	0	0	0	0	0	0	0	0	0	0	0	0	0	0	0001
D10001	0	0	0	0	0	0	0	0	0	0	0	0	0	0	0	0	0000
D10002	0	0	0	0	0	0	0	0	0	0	0	1	1	0	1	1	0037
D10003	0	0	0	0	0	0	0	0	0	0	0	0	0	0	0	0	0000
D10004	0	0	0	0	0	0	0	0	0	0	0	0	0	0	0	0	0000
D10005	0	0	0	0	0	0	0	0	0	0	0	0	0	0	0	0	0000
D10006	0	0	0	0	0	0	0	0	0	0	0	0	0	1	1	1	000E
D10007	0	0	0	0	0	0	0	0	0	0	0	0	0	0	0	0	0000
D10008	0	0	0	0	0	0	0	0	0	0	0	0	0	0	0	0	0000
D10009	0	0	0	0	0	0	0	0	0	0	0	0	0	0	0	0	0000
D10010	0	0	0	0	0	0	0	0	0	0	0	0	0	1	1	1	000E
D10011	0	0	0	0	0	0	0	0	0	0	0	0	0	0	0	0	0000
D10012	0	0	0	0	0	0	0	0	0	0	0	0	0	1	0	0	0010

- 12** Confirm that the values for **D10030** to **D10034** are as shown below.  
 [Decoded String: 123456]  
 D10030:0006 (DECODE\_LENGTH)  
 D10031:0000  
 D10032:3231 (String: "12")  
 D10033:3433 (String: "34")  
 D10034:3635 (String: "56")

Start Address:	10000	On	Off	SetValue													
ChangeOrder		ForceOn	ForceOff	ForceCanc													
	15	14	13	12	11	10	9	8	7	6	5	4	3	2	1	0	Hex
D10030	0	0	0	0	0	0	0	0	0	0	0	0	0	0	1	1	0006
D10031	0	0	0	0	0	0	0	0	0	0	0	0	0	0	0	0	0000
D10032	0	0	1	1	0	0	1	0	0	0	1	1	0	0	0	1	3231
D10033	0	0	1	1	0	1	0	0	0	0	1	1	0	0	1	1	3433
D10034	0	0	1	1	0	1	1	0	0	0	1	1	0	1	0	1	3635
D10035	0	0	0	0	0	0	0	0	0	0	0	0	0	0	0	0	0000
D10036	0	0	0	0	0	0	0	0	0	0	0	0	0	0	0	0	0000
D10037	0	0	0	0	0	0	0	0	0	0	0	0	0	0	0	0	0000
D10038	0	0	0	0	0	0	0	0	0	0	0	0	0	0	0	0	0000
D10039	0	0	0	0	0	0	0	0	0	0	0	0	0	0	0	0	0000
D10040	0	0	0	0	0	0	0	0	0	0	0	0	0	0	0	0	0000
D10041	0	0	0	0	0	0	0	0	0	0	0	0	0	0	0	0	0000
D10042	0	0	0	0	0	0	0	0	0	0	0	0	0	0	0	0	0000
D10043	0	0	0	0	0	0	0	0	0	0	0	0	0	0	0	0	0000

## 8. Initializing the System

In this document, it is assumed that the controller and the code reader uses the factory default settings.

If you change their settings from the defaults, you may not be able to perform various setting procedures as described.

### 8.1. Initializing the PLC

To initialize the controller, you must initialize the CPU Unit and EtherNet/IP Unit. Please put the PLC in PROGRAM mode before initialization.

#### 8.1.1. EtherNet/IP Unit

(1) In the CX-Programmer, select **Edit – I/O Table and Unit Setup** from the **PLC Menu**.

In the **PLC IO Table** Window, right-click on the EtherNet/IP Unit and select **Unit Setup** from the menu.

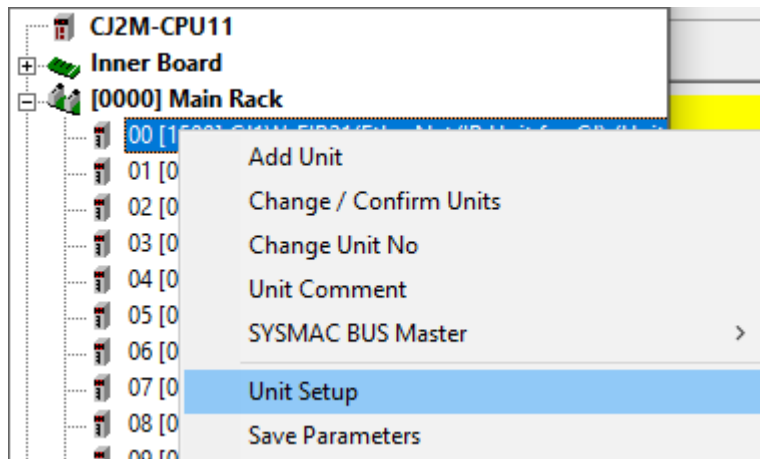

(2) In the Edit Parameters Dialog Box, click Restart.

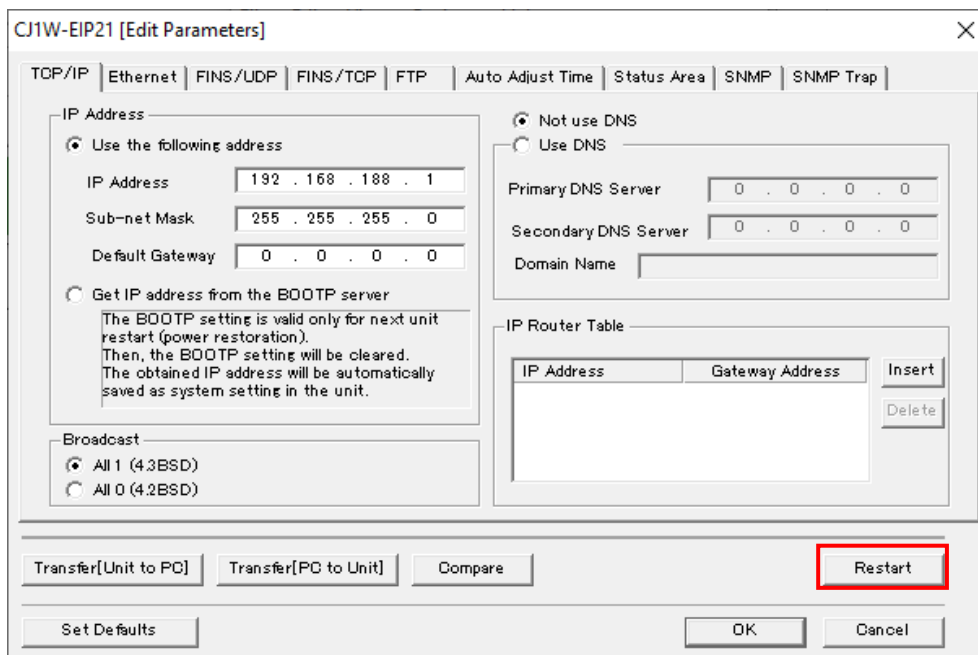

- (3) An execution confirmation dialog box appears. Confirm that there is no problem and click **Yes**. Next, the **Restart Unit** Dialog Box is displayed. Select **Return to out-of-box configuration, and then emulate cycling power** and click **OK**.  
An execution completion dialog box appears. Confirm the information and click **OK**.

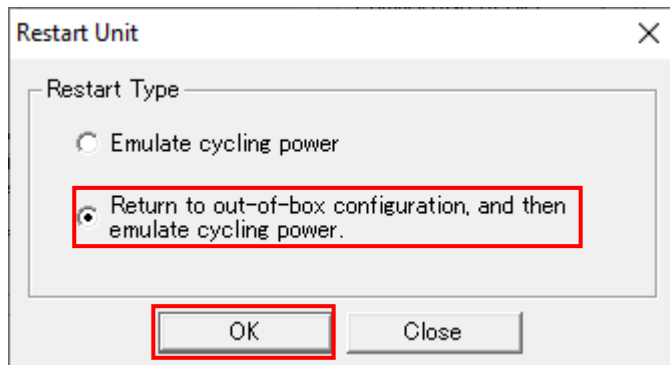

### 8.1.2. CPU Unit

To initialize the CPU Unit, select **Clear All Memory Areas** from the **PLC** Menu in the **CX-Programmer**. In the **Confirm All Memory Area Clear** Dialog Box, select **Initialize** and click **OK**.

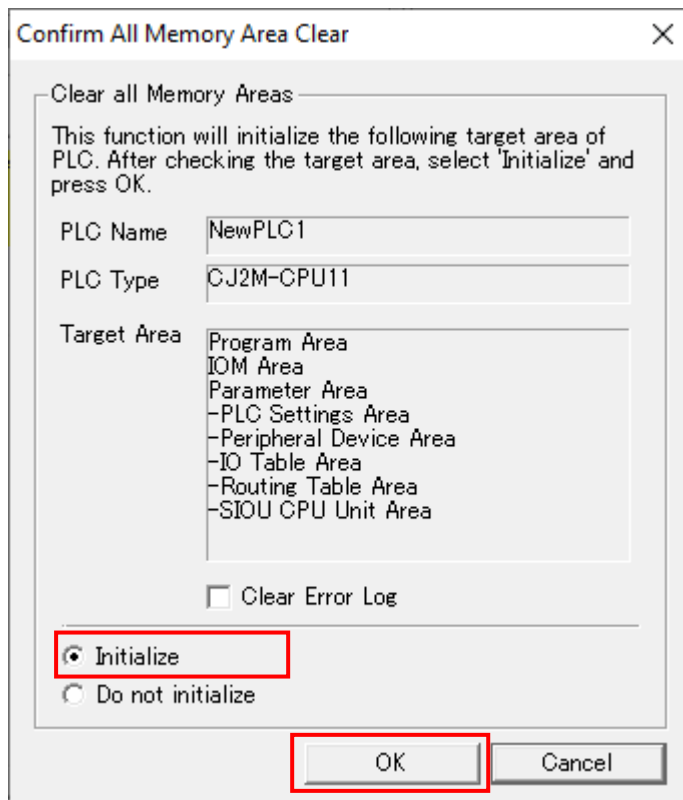

## 8.2. Initializing the Code Reader

For information on initializing the code reader, please refer to *How to initialize the settings?* in Q&A in Appendices of the *V460-H Industrial Handheld DPM Reader User Manual* (Cat. No. Z461).



## 9. Appendices How to Use the Project File

This section explains the procedure for using the following project file. The project file contains the settings described in 7.3. *PLC Setup*.

Obtain the latest version of the project file from OMRON Corporation.

Name	Filename	Version
CX-Programmer Project File (Ladder Program) (Extension: cxp)	OMRON_V460_CJ_EIP_V100.cxp	Ver. 1.00

### 9.1. Operation Flow

The procedures for setting up the EtherNet/IP tag data links using the project file are as follows.

Refer to the respective sections, except for 9.2.1. *Loading the Project File* shown in the red frame.

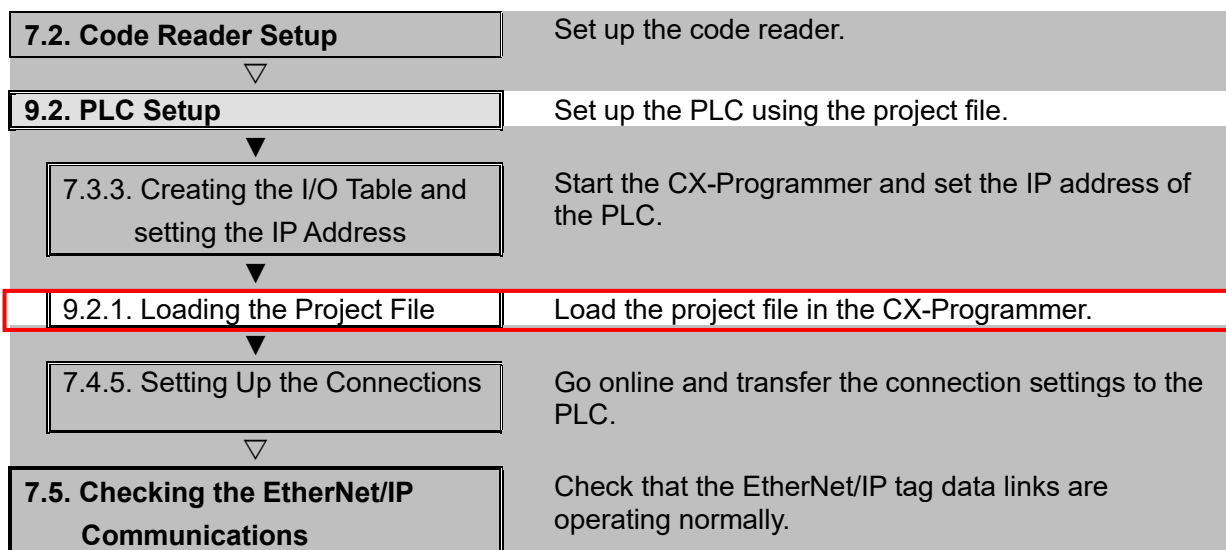

## 9.2. PLC Setup

Set up the PLC using the project file.

### 9.2.1. Loading the Project File

Load the project file in the CX-Programmer.

- 1 Select **Open** from the **File** Menu.

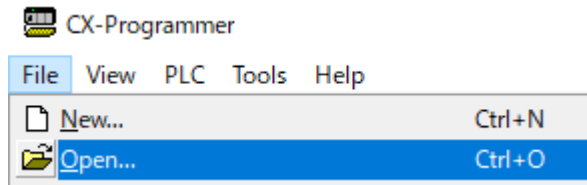

- 2 The **Import file** Dialog Box is displayed. Select the project file **OMRON\_V460\_CJ\_EIP\_V100.cxp** and click **Open**.

\* Obtain the latest version of the project file from the OMRON Corporation.

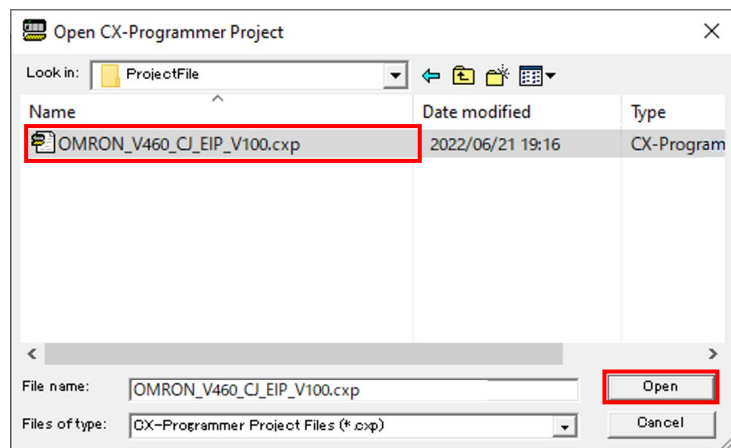

- 3 The Project Screen is displayed.

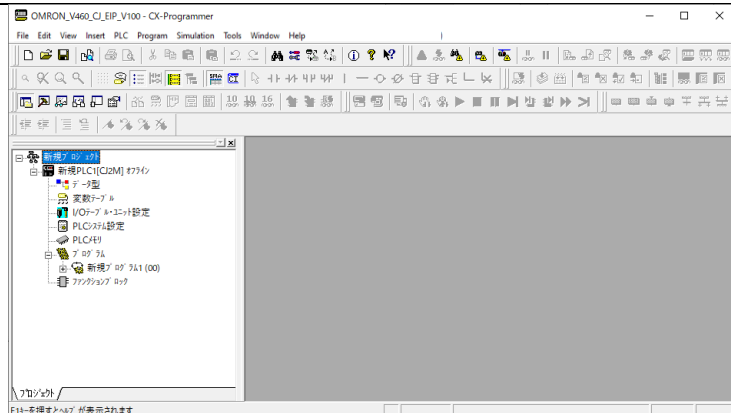

- 4 Select the new PLC with the operating mode indication.

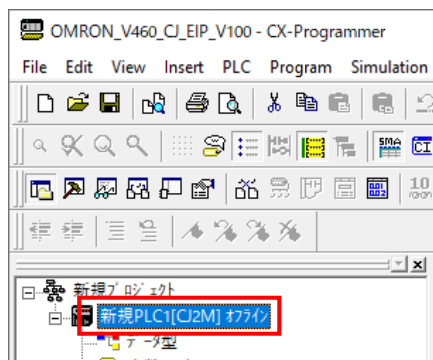

**5** Select **Change Model** from the PLC Menu.

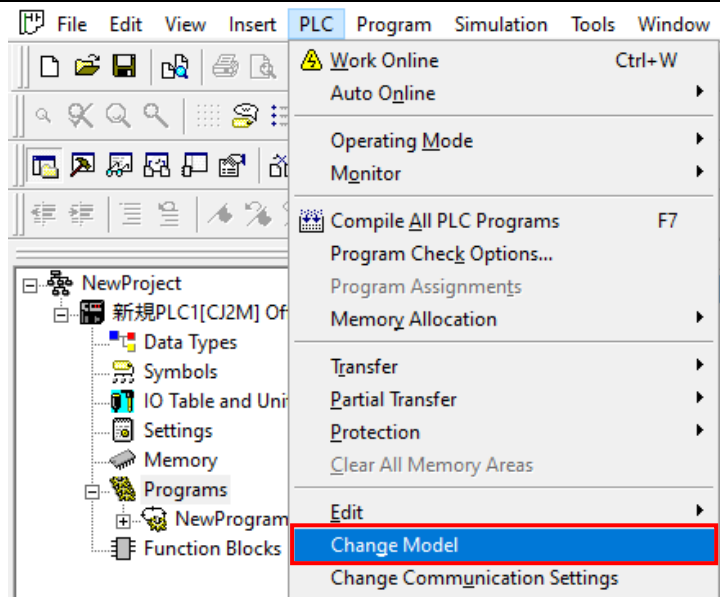

**6** The **Change PLC** Dialog Box is displayed.

In **Device Type**, confirm the PLC is selected as shown in the figure on the right, and click **Settings** to check its settings so that you can use it.

Click **Cancel**.

\* If using a different PLC model, select it from the pull-down menu, click **Settings** to change its settings, and click **OK**.

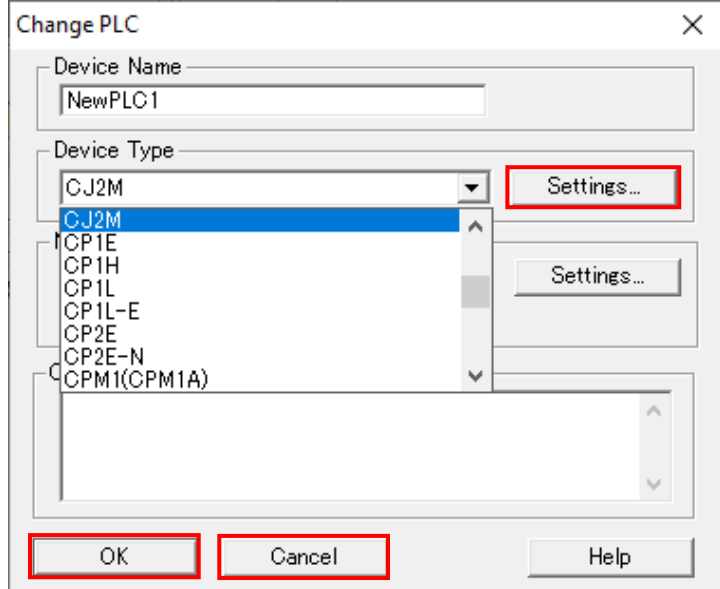

## 10. Revision History

Revision Code	Revision Date	Revised Page and Reason
01	November 2023	First Publication



**OMRON Corporation Industrial Automation Company**

**Kyoto, JAPAN**

**Contact : [www.ia.omron.com](http://www.ia.omron.com)**

**Regional Headquarters**

**OMRON EUROPE B.V.**

Wegalaan 67-69, 2132 JD Hoofddorp  
The Netherlands  
Tel: (31) 2356-81-300 Fax: (31) 2356-81-388

**OMRON ASIA PACIFIC PTE. LTD.**

438B Alexandra Road, #08-01/02 Alexandra  
Technopark, Singapore 119968  
Tel: (65) 6835-3011 Fax: (65) 6835-3011

**OMRON ELECTRONICS LLC**

2895 Greenspoint Parkway, Suite 200  
Hoffman Estates, IL 60169 U.S.A.  
Tel: (1) 847-843-7900 Fax: (1) 847-843-7787

**OMRON (CHINA) CO., LTD.**

Room 2211, Bank of China Tower,  
200 Yin Cheng Zhong Road,  
PuDong New Area, Shanghai, 200120, China  
Tel: (86) 21-6023-0333 Fax: (86) 21-5037-2388

**Authorized Distributor:**

©OMRON Corporation 2023 All Rights Reserved.  
In the interest of product improvement,  
specifications are subject to change without notice.

**Cat. No. Z478-E1-01 1123**